

Toolspress

high quality tooling systems



C&P ENGINEERING
PROCUREMENT LDA

www.cep-ep.pt | info@cep-ep.pt

tools  **press**

BYSTRONIC STYLE

Press Brake Tooling

www.toolspress.com

toolspress

Spirito d'Innovazione

Toolspress è leader mondiale nella progettazione e produzione di utensili e sistemi di bloccaggio di alta qualità, per presse piegatrici. Realizziamo prodotti all'avanguardia ed innovativi, sfruttando 30 anni di esperienza ed un ampio programma di produzione, con più di mille modelli standard, che ci permettono di valutare e risolvere le problematiche proposte, ottimizzando i vostri sistemi di piegatura.

Toolspress è composta da Quattro importanti divisioni:

- Utensili Standard di Alta Precisione per Presse Piegatrici
- Utensili Speciali di Alta Precisione per Presse Piegatrici
 - Sistemi di Bloccaggio per Presse Piegatrici
 - Soluzioni Industriali per Presse Piegatrici
 - Lame da cesoia

Queste quattro divisioni sono indipendenti e utilizzano le tecnologie più avanzate disponibili nel mercato mondiale, in questo modo possiamo garantire prodotti di alta qualità senza paragoni. La qualità Toolspress è ben conosciuta nel mercato mondiale da molti anni. I nostri clienti sono per noi partners tecnologici, grazie ad una stretta collaborazione, risolviamo e incrementiamo le loro performance di piegatura. Il mercato globale richiede sempre più tecnologia a prezzi molto competitivi e nel minor tempo possibile, per questi motivi la nostra società ricerca e sviluppa metodi di produzione che ci permettono di soddisfare le richieste dei nostri clienti.

The Spirit of Innovation

Toolspress is a world-class designer and manufacturer of high-quality press brake tooling and clamping system. We provide the most innovative products in the fabricators industries. Through a great manufacturing program with more than thousand standard model, we are able to guide your choice of the best bending system in the fastest time, due to the long experience we got in 30th years.

Toolspress has four important divisions:

- Precision Ground Standard Press Brakes Tooling
- Precision Ground Special Press Brakes Tooling
 - Press Brakes Clamping System
 - Industrial Solutions for Press Brakes
 - Shear blades

These four divisions are independent and both use the ultimate technologies in manufacturing process available in the world market, in this way we can guarantee high precision quality products with no comparison. Toolspress quality is very well known in the world market since many years. Our customers are for us technological partners, in fact through a tight cooperation they let us solve and improve their bending performance. The global market needs always more and more technology to a very competitive prices in the shortest time. In this way our company develops manufacturing methods that allow us to meet our costumers requirements.

The Spirit of Innovation

Toolspress® ist der weltweit führende Entwickler und Hersteller von qualitativ hochwertigen Abkantwerkzeugen und Werkzeug-Spannsysteme. Wir entwickeln und vertreiben die innovativsten Produkte im Bereich der Abkantttechnik. Durch unser großes Herstellungsprogramm mit über tausend Standardwerkzeugen sind wir in der Lage, das von Ihnen gewünschten Werkzeugsystem innerhalb kürzester Zeit zu liefern. Toolspress® verfügt über eine 30-jährige Erfahrung in der Abkantttechnik.

Toolspress® hat vier wichtige Bereiche:

- Präzisions Standard Abkantwerkzeuge
- Präzisions Spezial Abkantwerkzeuge
- Spannsysteme für Abkantwerkzeuge
- Industrielle Lösungen für Abkantpressen
 - Shear blades

Diese vier Bereiche sind unabhängig, aber alle nutzen die neuesten auf dem Weltmarkt verfügbaren Fertigungstechnologie. Auf diese Weise können wir hochpräzise Qualitätsprodukte ohne Kompromisse garantieren. Die Qualität von Toolspress® ist seit Jahren auf dem Markt bekannt.

Für uns sind unsere Kunden technologische Partner. In enger Zusammenarbeit werden Lösungen erreicht und Abkanttleistungen verbessert. Die globalen Marktanforderungen fordern immer mehr Technologien, zu wettbewerbsfähigen Preisen, in kürzester Zeit. Daher entwickeln wir ständig neue Herstellungsverfahren, die es uns erlauben den Kundenanforderungen zu entsprechen.



Order	Minimum order is 100 €
Credit	All orders are subject to the approval of our credit department. If you are a new account, please furnish us with a bank reference and three supplier references. A credit limit will be imposed on new accounts until credit has been established.
Payment	Terms are net 30 days.
Cancellation	In the event an order is cancelled, a charge will be made to cover labour, materials and overheads.
Returned Material	A handling charge of 25% is made on all standard parts returned for credit. Written permission and shipping instructions must be obtained before the return of any material. Special tooling cannot be returned.
Claims	All claims for shortages must be made within 3 days of the invoice date.
Prices	Prices and specifications subject to change without prior notice. E & O E. All prices are exclusive of VAT.
Delivery Charge	All orders are subject to a delivery charge. Please call the sales desk for a delivery quotation.

Standard Punch Lengths

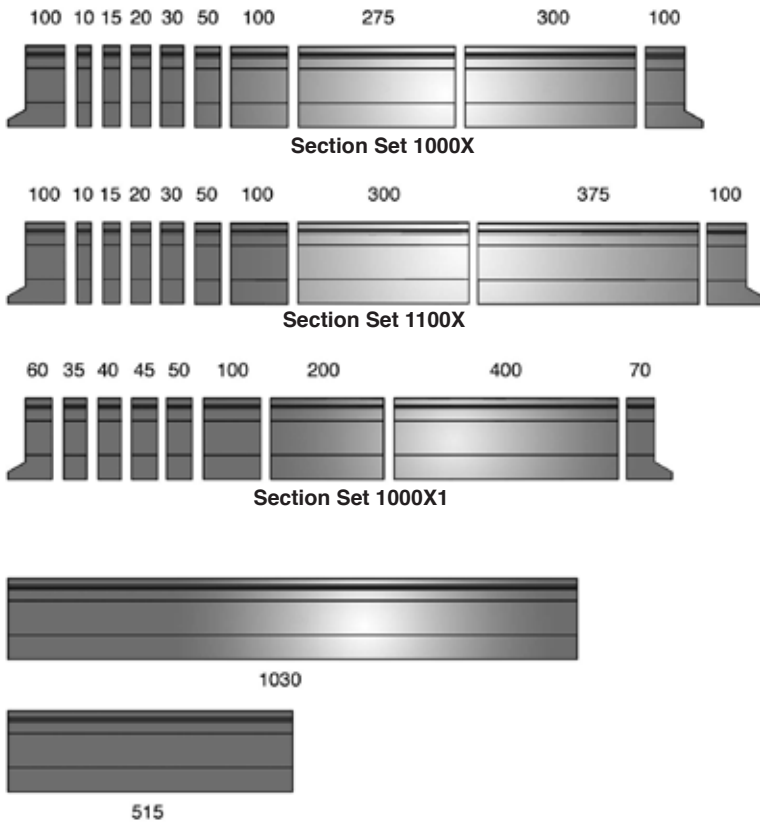

Features:

- All punches made from 42CrMo4
- Sectionalised set includes 2 ear pieces (horns)
- Punches are induction hardened to 58HRC
- Minimum hardness depth on punch tip = 4mm

To order put the required number after the part no.

XXXXXXXX - 1000X
or - 1100X
or - 1000X1

e.g IB0588010 - 1100X

Standard Die Lengths

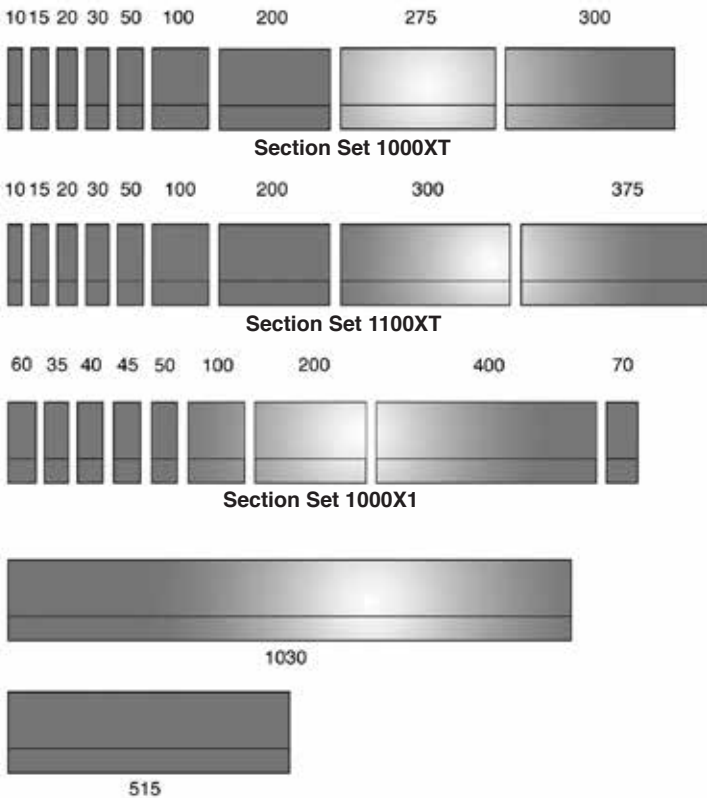

Features:

- Dies induction hardened to 58HRC on working areas
- Minimum hardness depth = 4mm
- All dies made from 42CrMo4

To order put the required number after the part no.

XXXXXXXX - 1000XT
or - 1100XT
or - 1000X1

e.g IB0588010 - 1100X



Bystronic R

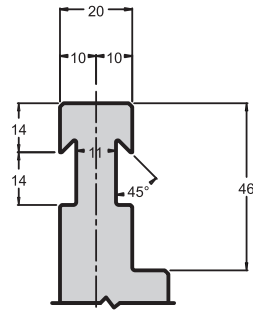

Bystronic RFA

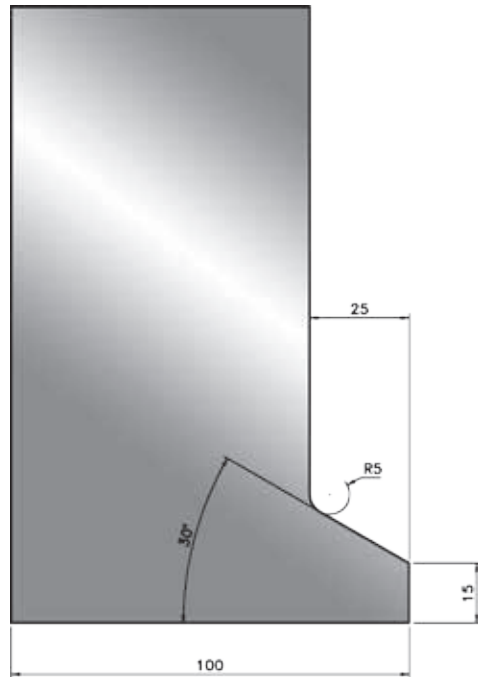
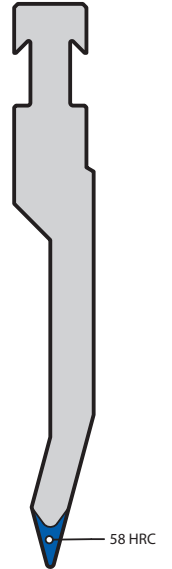
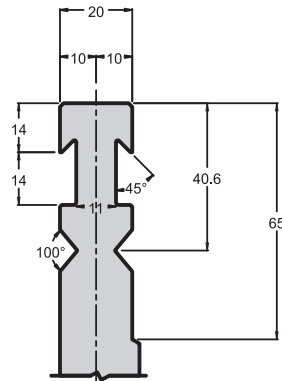

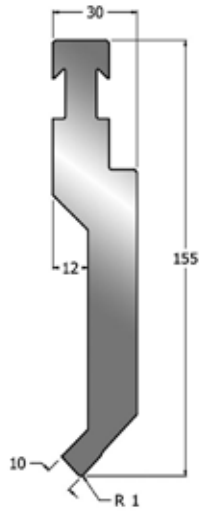

85/88° Gooseneck
IB0185010
IB0188010
Max Force: 1000 kN/m
Bystronic Profile P2R

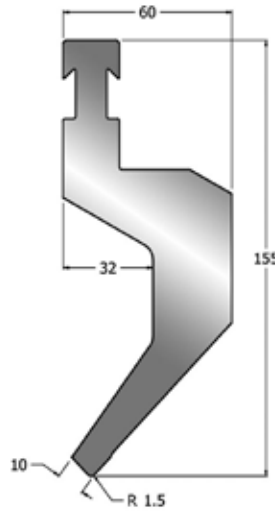

85/88° Swan Neck
IB0085015
IB0088015
Max Force: 700 kN/m
Bystronic Profile P4R

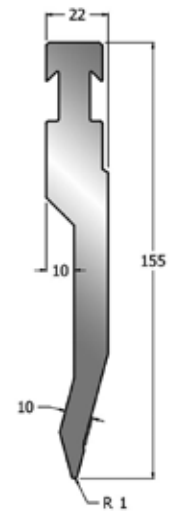

30° Acute Goose Neck
IB0230010

Max Force: 1000 kN/m
Bystronic Profile P5R

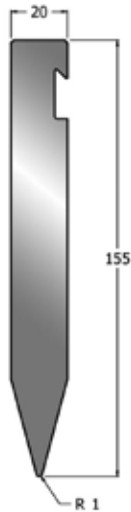

30° Pointed
IB0430010

Max Force: 1500 kN/m
Bystronic Profile P6R

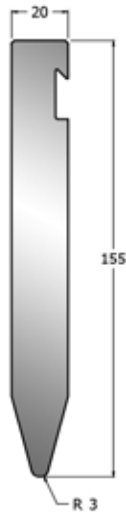

30° Pointed
IB0430030

Max Force: 1500 kN/m
Bystronic Profile P7R

For different Radii & Relief consult Tools Press

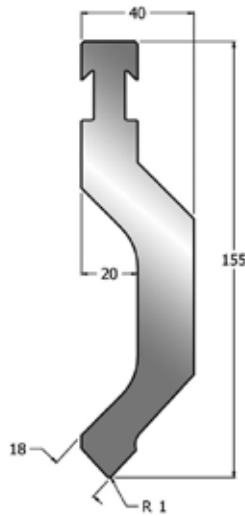

85°/88° Shallow Swan Neck

IB0585010
IB0588010
Max Force: 1000 kN/m
Bystronic Profile P8R

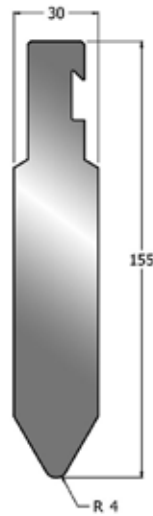

60° Pointed

IB0460040
Max Force: 2000 kN/m
Bystronic Profile P9R

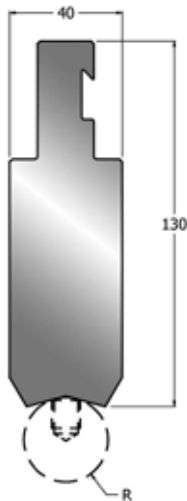

Radius Tools Available
Consult Tools Press for
more details

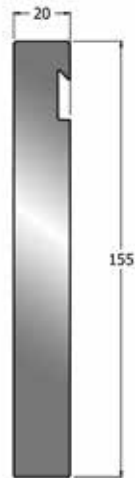

Flattening Tools Available
Consult Tools Press for
more details

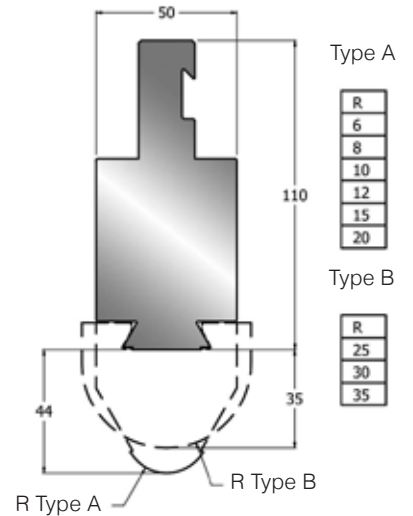

Keyed Radius Tools Available
Consult Tools Press for
more details

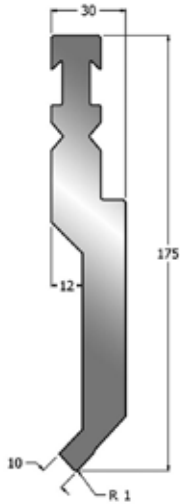

85°/88° Gooseneck
 IB1185010
 IB1188010
 Max Force: 1000 kN/m
 Bystronic Profile P2RFA

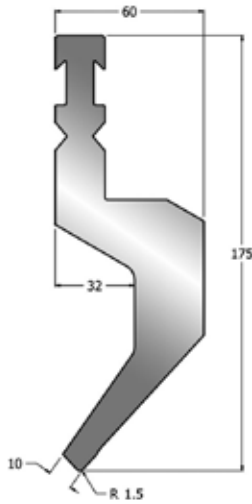

85°/88° Swan Neck
 IB1085015
 IB1088015
 Max Force: 700 kN/m
 Bystronic Profile P4RFA

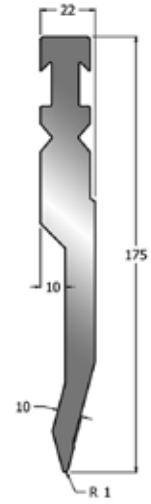

30° Acute Goose Neck
 IB1230010

 Max Force: 1000 kN/m
 Bystronic Profile P5RFA



30° Pointed
 IB1430010

 Max Force: 1500 kN/m
 Bystronic Profile P6RFA



30° Pointed
 IB1430030

 Max Force: 1500 kN/m
 Bystronic Profile P7RFA

For different Radii & Relief consult Tools Press

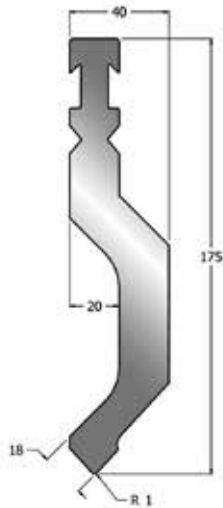

85°/88° Shallow Swan Neck

IB1585010
IB1588010
Max Force: 1000 kN/m
Bystronic Profile P8RFA

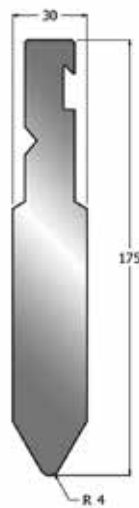

60° Pointed

IB1460040
Max Force: 1600 kN/m
Bystronic Profile P9RFA

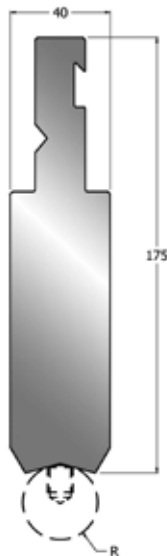

Radius Tools Available
Consult Tools Press for
more details



Flattening Tools Available
Consult Tools Press for
more details

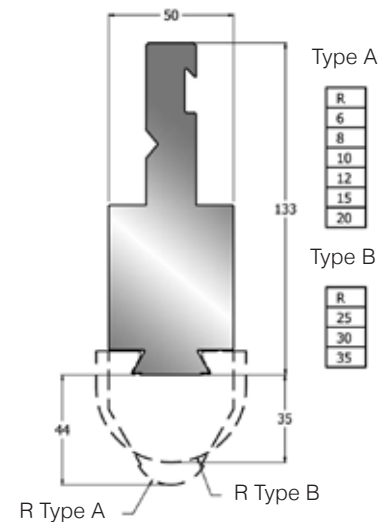

Keyed Radius Tools Available
Consult Tools Press for more
details

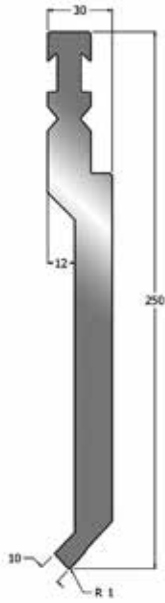

85°/88° Gooseneck
IB2185010
IB2188010
Max Force: 1000 kN/m
Bystronic Profile P2RFA

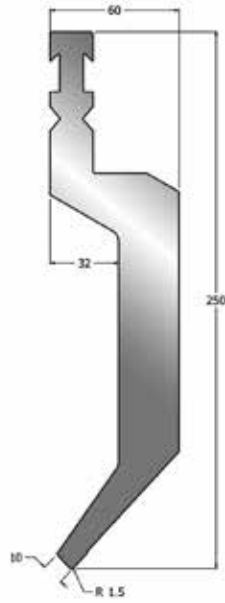

85°/88° Swan Neck
IB2085015
IB2088015
Max Force: 600 kN/m
Bystronic Profile P4RFA

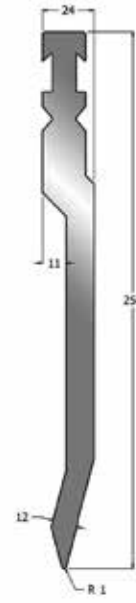

30° Acute Goose Neck
IB2230010

Max Force: 750 kN/m
Bystronic Profile P5RFA



30° Pointed
IB2430010
Max Force: 1400 kN/m
Bystronic Profile P6RFA



30° Pointed
IB2430030
Max Force: 1400 kN/m
Bystronic Profile P7RFA



60° Pointed
IB2460040
Max Force: 1600 kN/m
Bystronic Profile P9RFA

For different Radii & Relief consult Tools Press

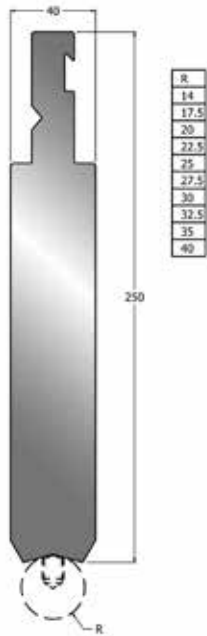

Radius Tools Available
Consult Tools Press for
more details



Flattening Tools Available
Consult Tools Press for
more details

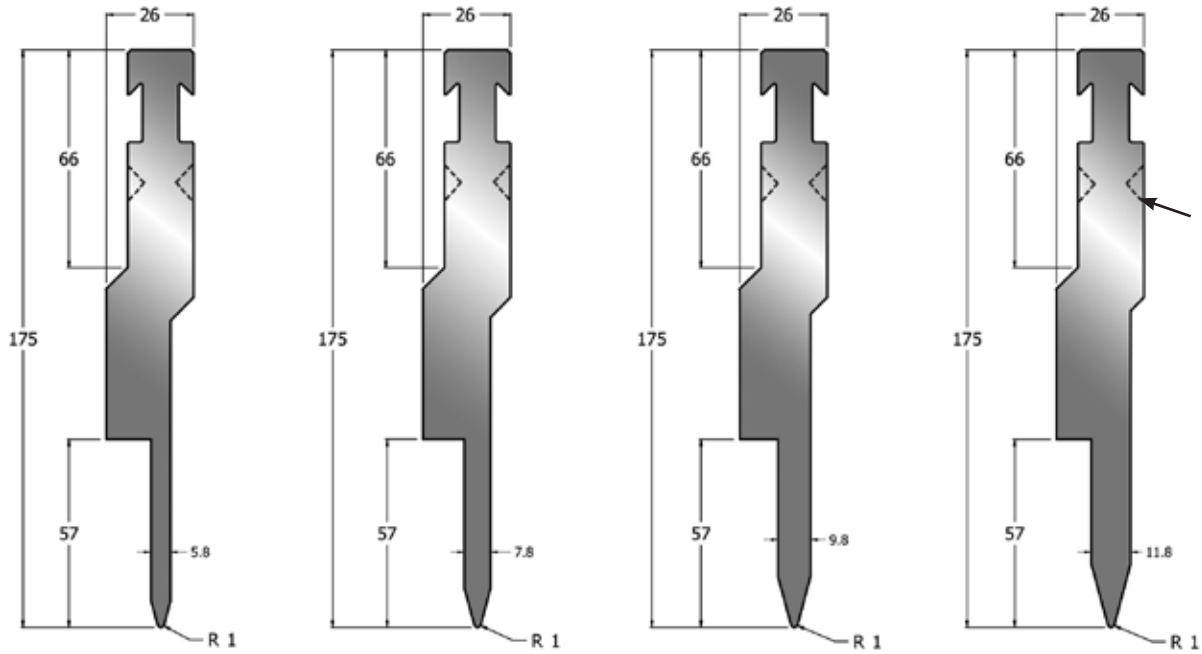

RFA Punches include 'V' grooves

R= IB0330010 - 6
RFA= IB1330010 - 6
Max Force:
Bending 500 kN/m
Flattening 1000 kN/m

R= IB0330010 - 8
RFA= IB1330010 - 8
Max Force:
Bending 700 kN/m
Flattening 1000 kN/m

R= IB0330010 - 10
RFA= IB1330010 - 10
Max Force:
Bending 1000 kN/m
Flattening 1000 kN/m

R= IB0330010 - 12
RFA= IB1330010 - 12
Max Force:
Bending 1000 kN/m
Flattening 1000 kN/m

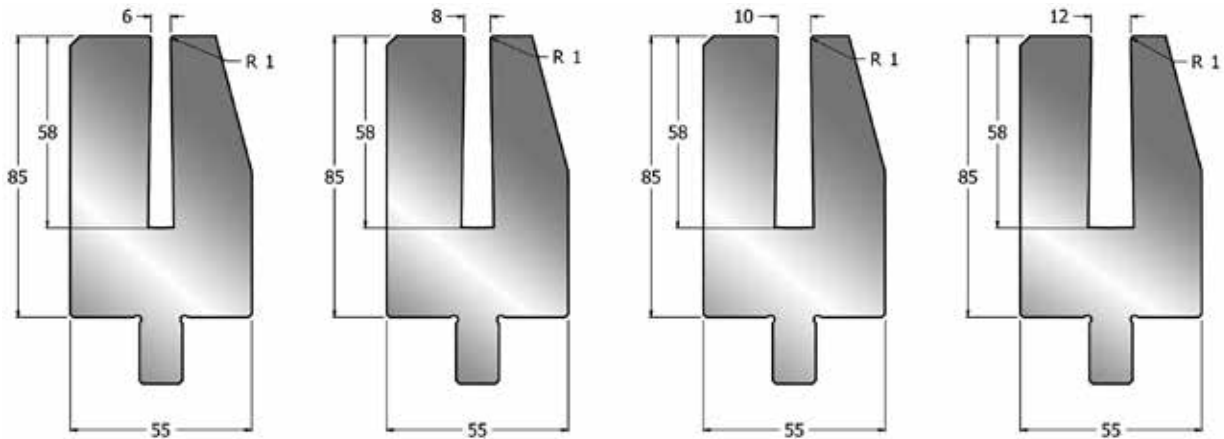

IB5330006
Max Force:
Bending 550 kN/m
Flattening 1000 kN/m

IB5330008
Max Force:
Bending 550 kN/m
Flattening 1000 kN/m

IB5330010
Max Force:
Bending 550 kN/m
Flattening 1000 kN/m

IB5330012
Max Force:
Bending 550 kN/m
Flattening 1000 kN/m

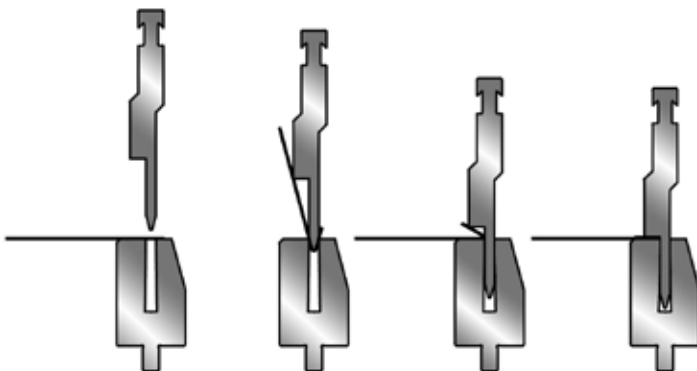

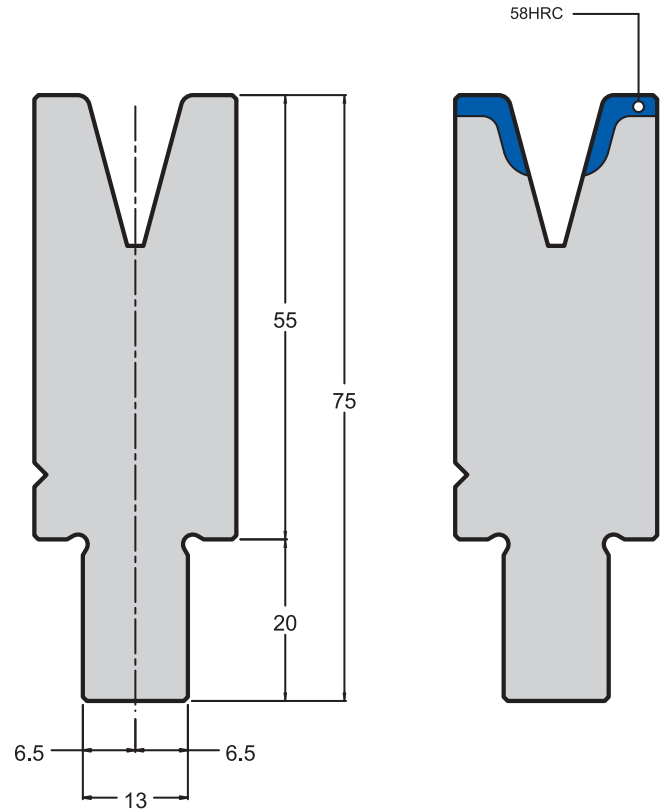
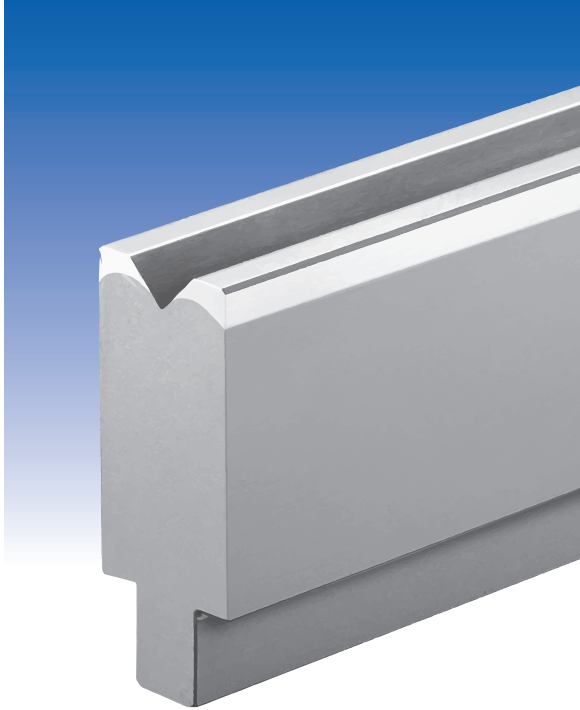

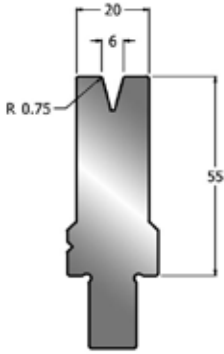

IB5030006
Max Force kN/m
Bend to 90° = 1000
30° = 400

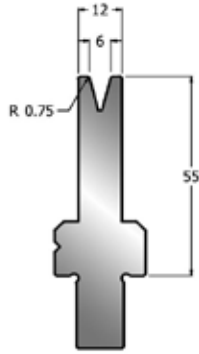

IB5130006
Max Force kN/m
Bend to 90° = 400
30° = 100

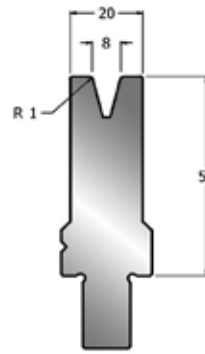

IB5030008
Max Force kN/m
Bend to 90° = 1000
30° = 300

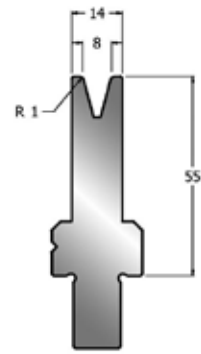

IB5130008
Max Force kN/m
Bend to 90° = 400
30° = 100

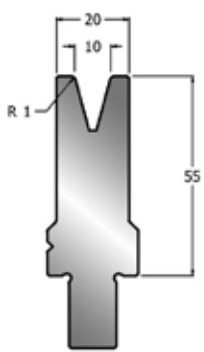

IB5030010
Max Force kN/m
Bend to 90° = 700
30° = 200

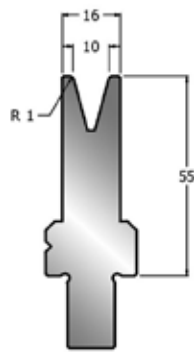

IB5130010
Max Force kN/m
Bend to 90° = 400
30° = 100

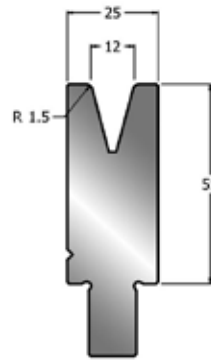

IB5030012
Max Force kN/m
Bend to 90° = 900
30° = 250

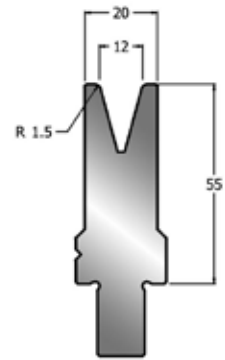

IB5130012
Max Force kN/m
Bend to 90° = 400
30° = 100

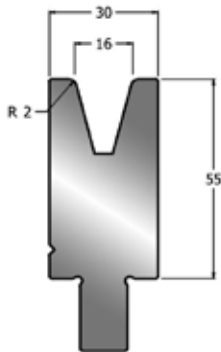

IB5030016
Max Force kN/m
Bend to 90° = 1000
30° = 250

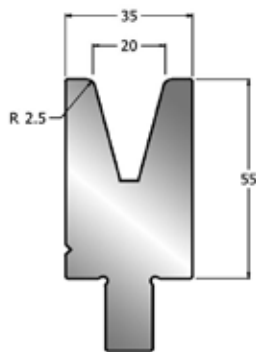

IB5030020
Max Force kN/m
Bend to 90° = 600
30° = 150

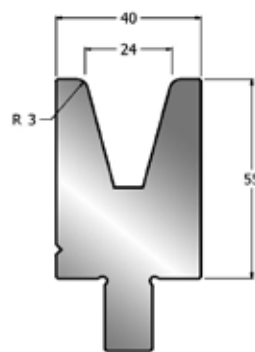

IB5030024
Max Force kN/m
Bend to 90° = 1100
30° = 300

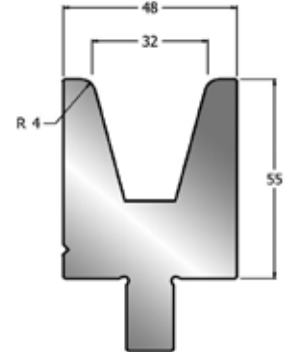

IB5030032
Max Force kN/m
Bend to 90° = 1100
30° = 300

All dies induction hardened

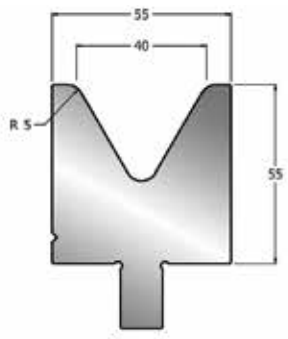

IB5060040
60°
Max Force kN/m
Bend to 90° = 1800
60° = 1000

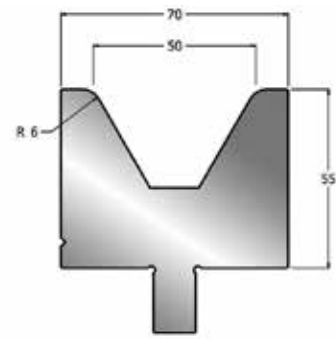

IB5060050
60°
Max Force kN/m
Bend to 90° = 1800
60° = 1000

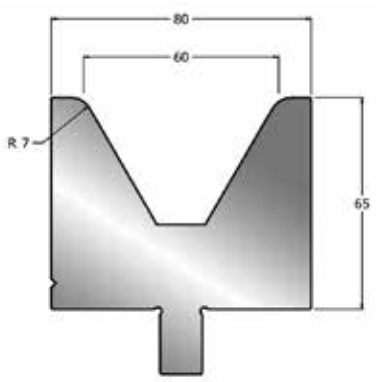

IB5060060
60°
Max Force kN/m
Bend to 90° = 1600
60° = 900

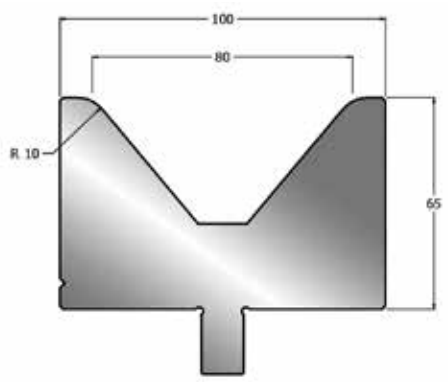

IB5080080
80°
Max Force kN/m
Bend to 90° = 1600
80° = 1400

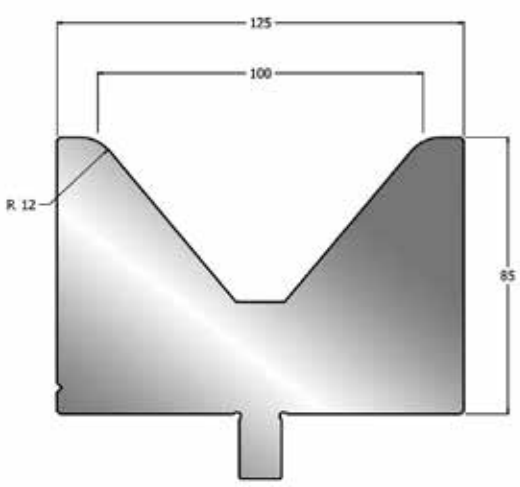

IB5080100
80°
Max Force kN/m
Bend to 90° = 2000
80° = 1800

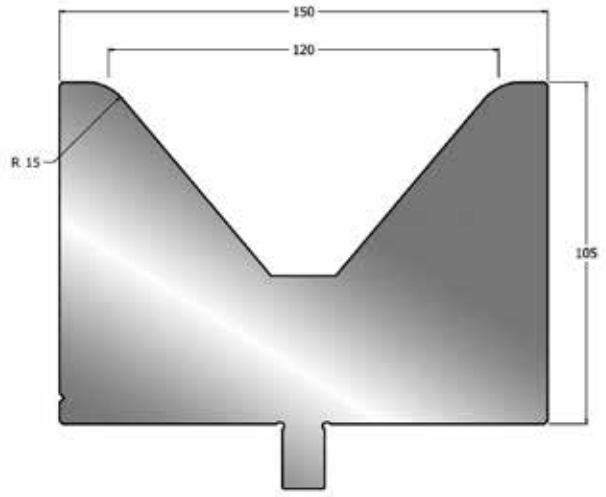

IB5080120
80°
Max Force kN/m
Bend to 90° = 2400
80° = 2000

All dies induction hardened

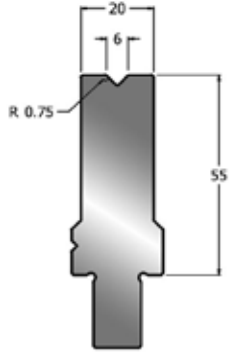

IB5085006
IB5088006
85°/88°
Max Force = 1000 kN/m

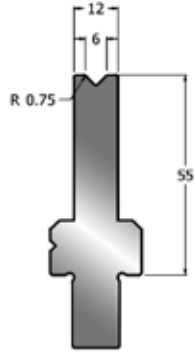

IB5185006
IB5188006
85°/88°
Max Force = 900 kN/m

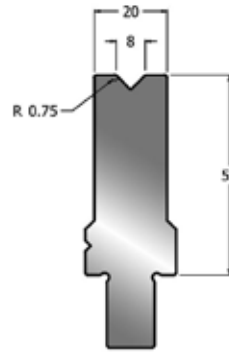

IB5085008
IB5088008
85°/88°
Max Force = 1000 kN/m

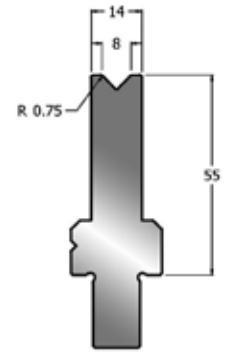

IB5185008
IB5188008
85°/88°
Max Force = 900 kN/m

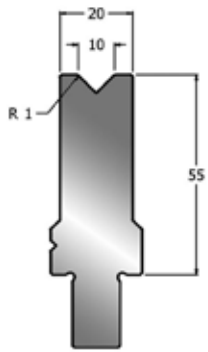

IB5085010
IB5088010
85°/88°
Max Force = 1000 kN/m

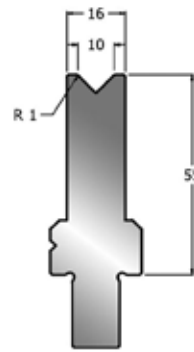

IB5185010
IB5188010
85°/88°
Max Force = 800 kN/m

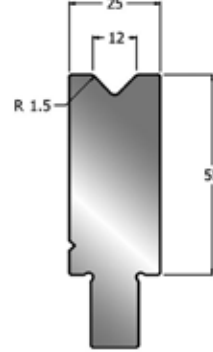

IB5085012
IB5088012
85°/88°
Max Force = 1000 kN/m

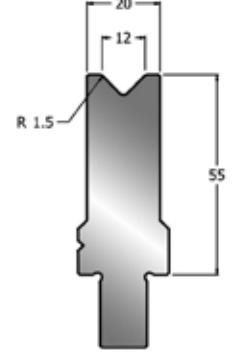

IB5185012
IB5188012
85°/88°
Max Force = 700 kN/m

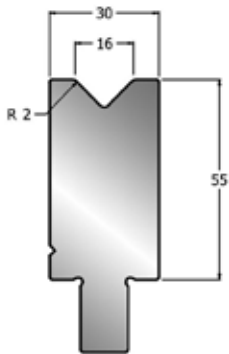

IB5085016
IB5088016
85°/88°
Max Force = 1000 kN/m

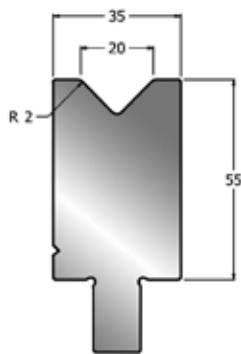

IB5085020
IB5088020
85°/88°
Max Force = 1000 kN/m

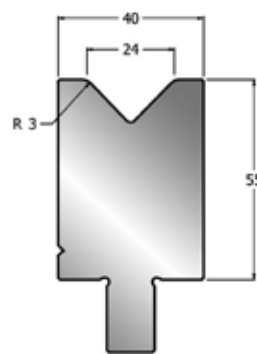

IB5085024
IB5088024
85°/88°
Max Force = 1000 kN/m

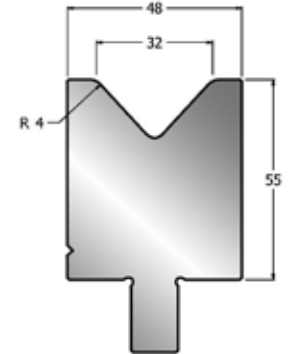

IB5085032
IB5088032
85°/88°
Max Force = 1000 kN/m

All dies induction hardened

Adaptor R-EuroA

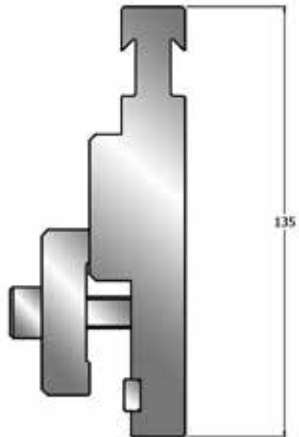

Adaptor R-EuroB

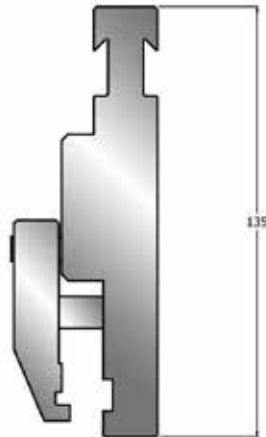

Adaptor R-R

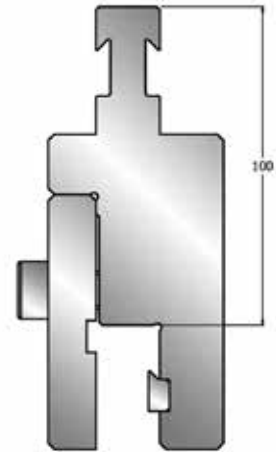

Adaptor R-S

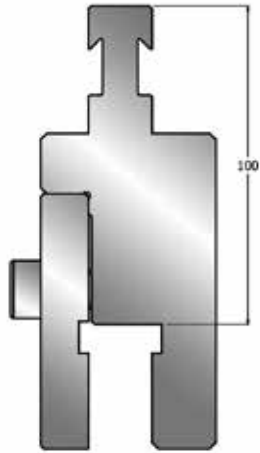

Adaptor R-RFA

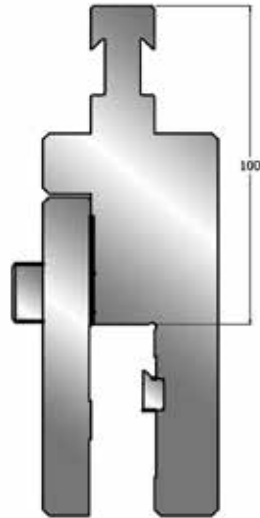

Adaptor RFA-EuroA

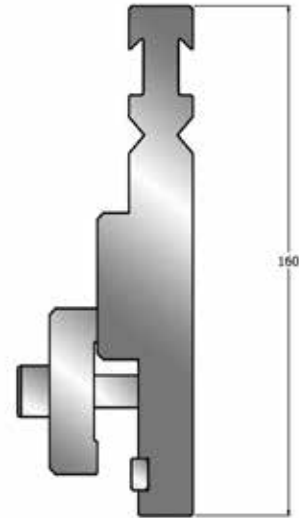

Adaptor RFA-EuroB

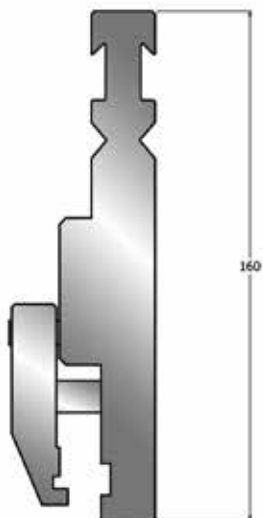

Adaptor RFA-R

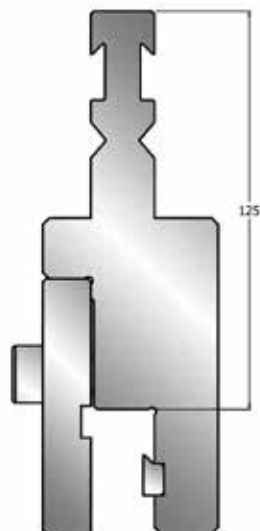

Adaptor RFA-RFA

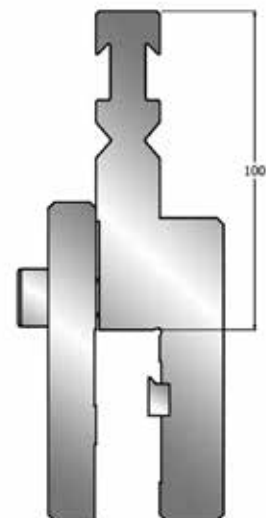

For adaptors consult Tools Press

IB0188010, IB0185010

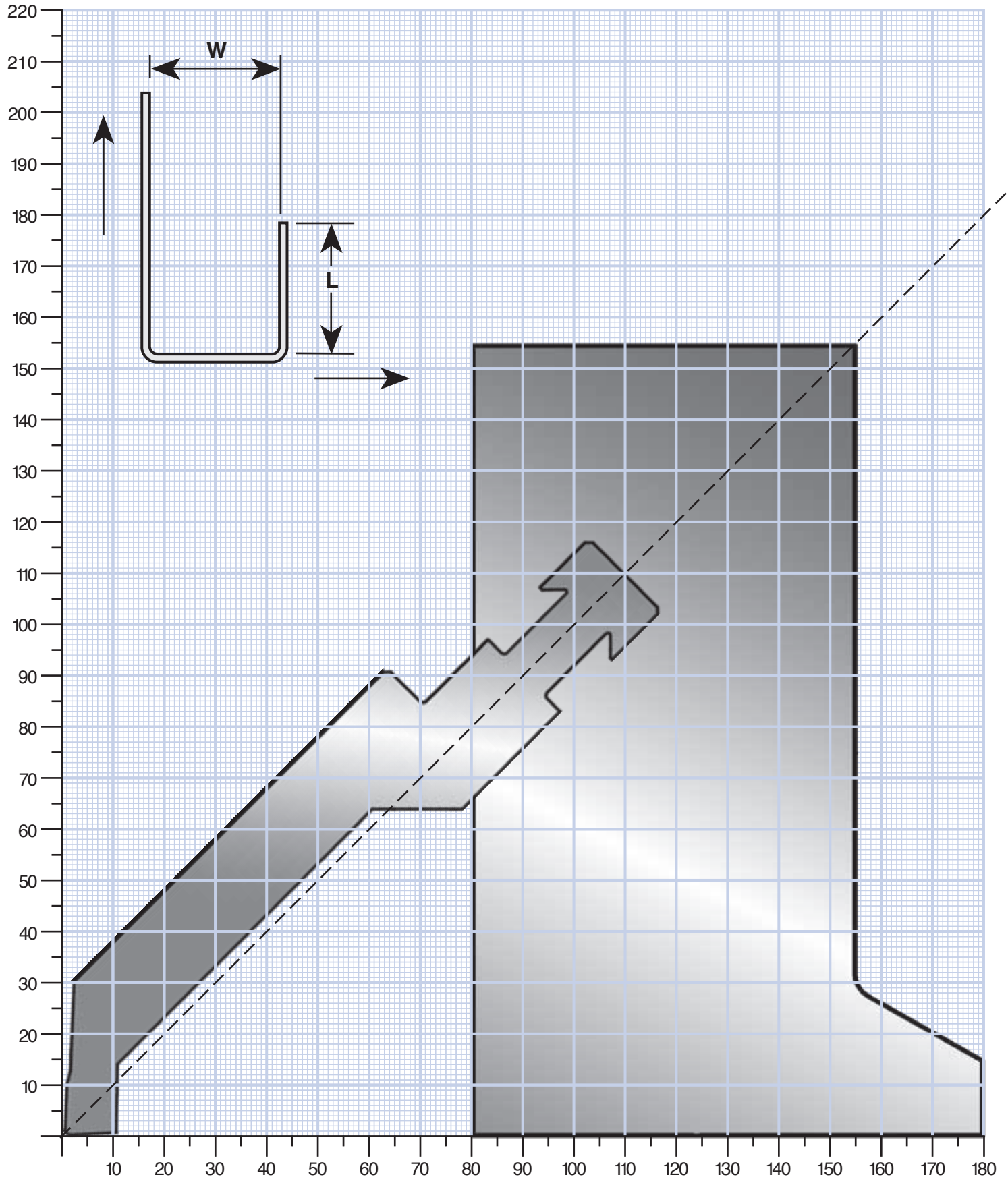

IB0088015, IB0085015

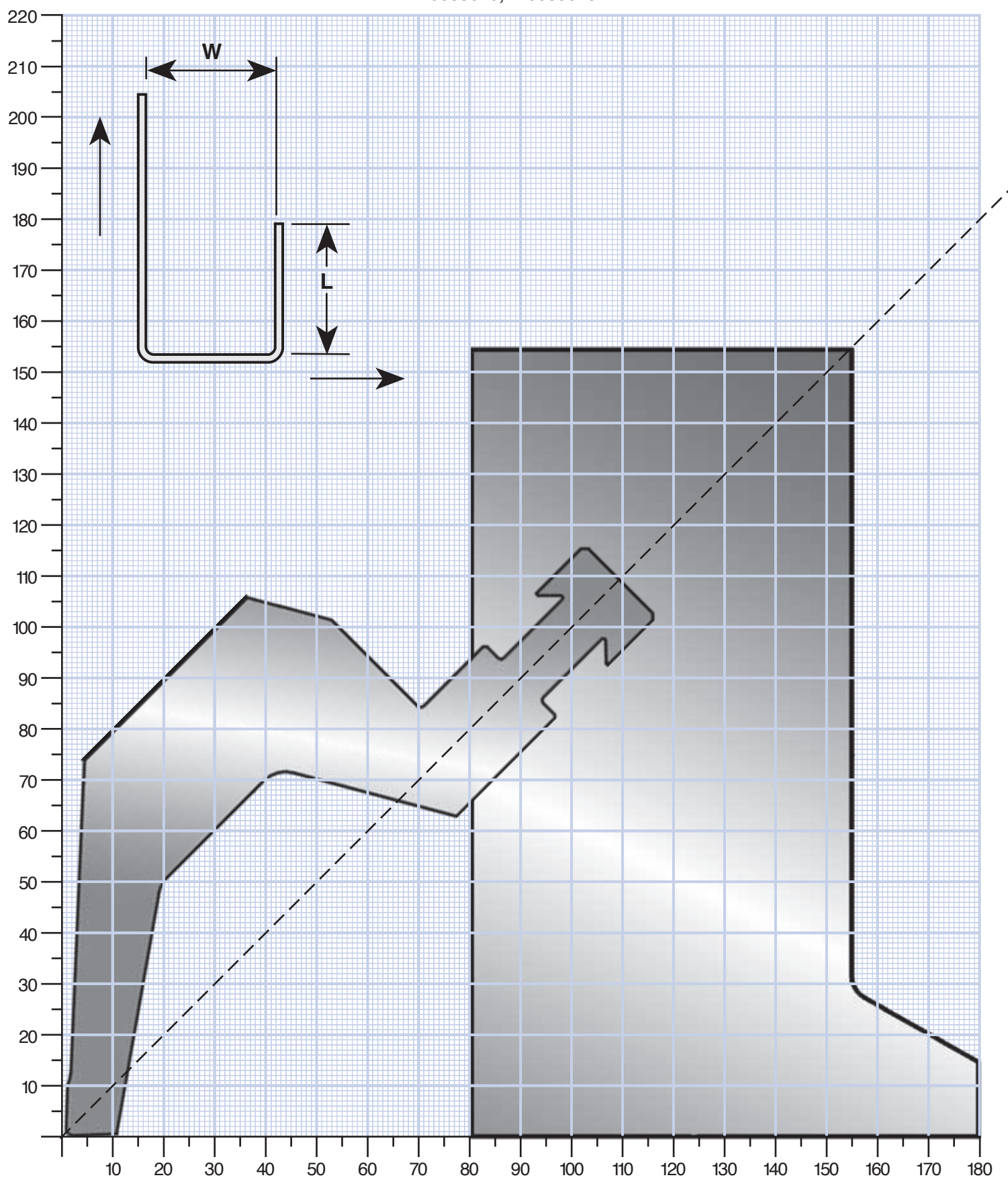

IB0230010

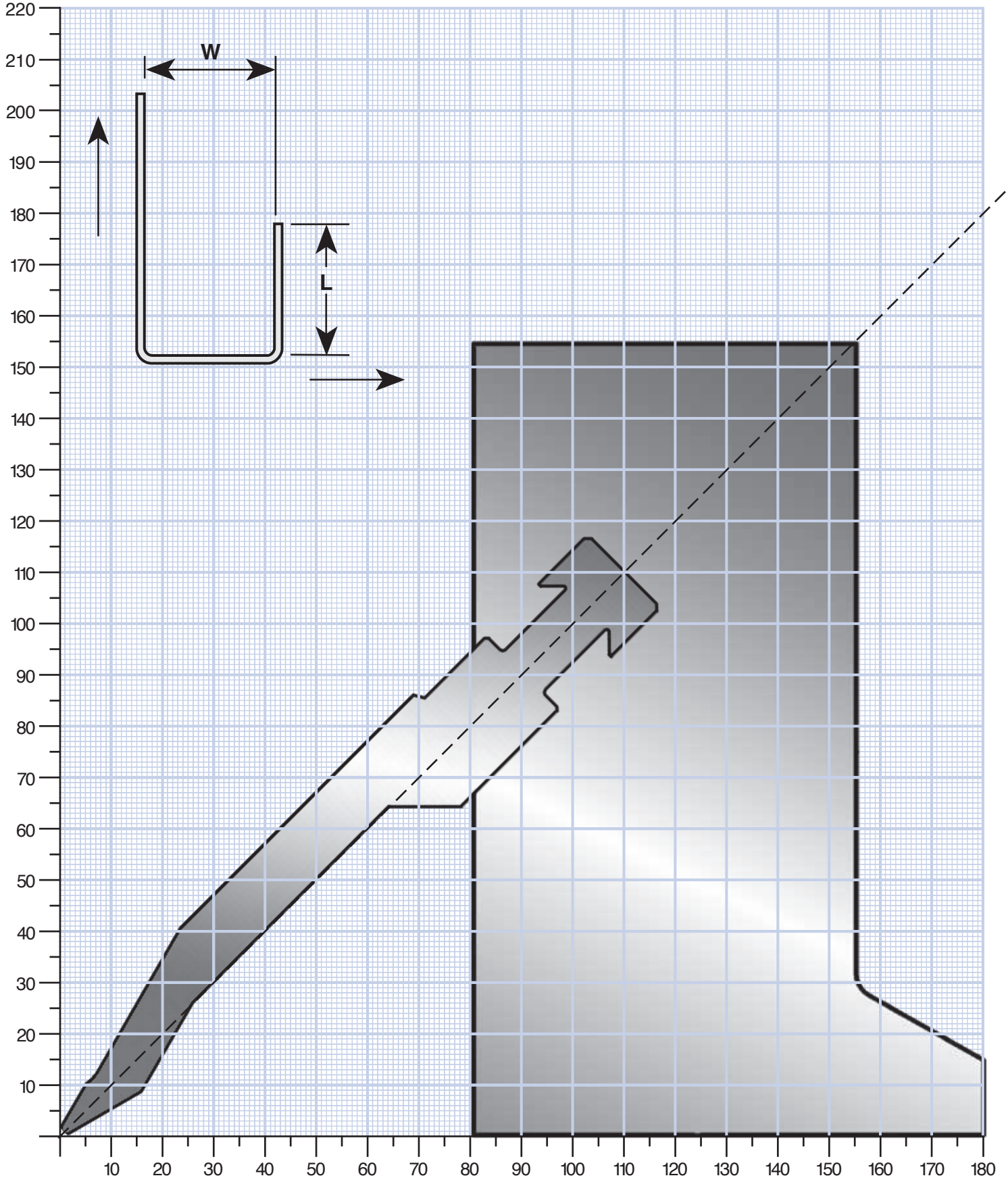

IB0430010

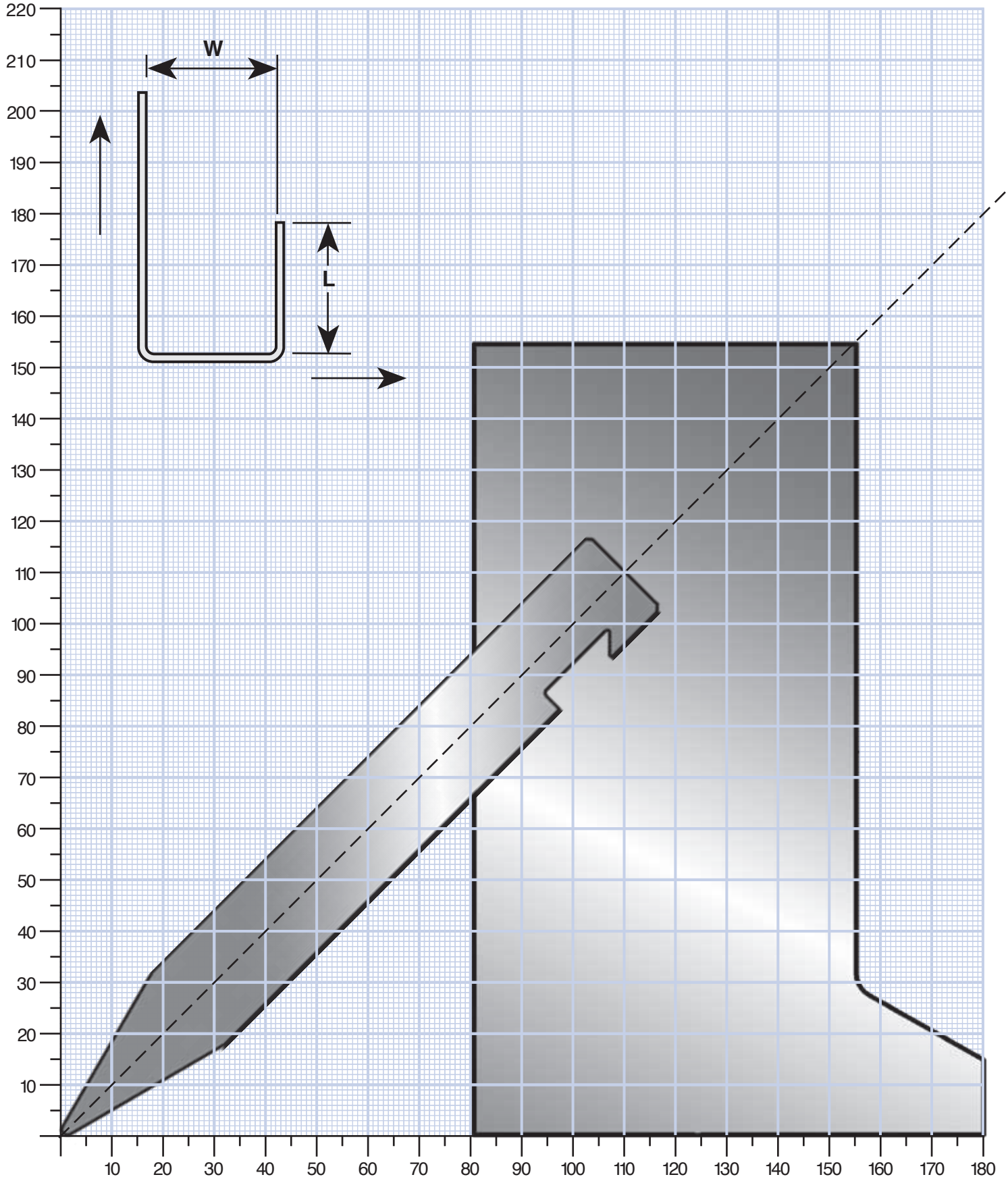

IB0588010, IB0585010

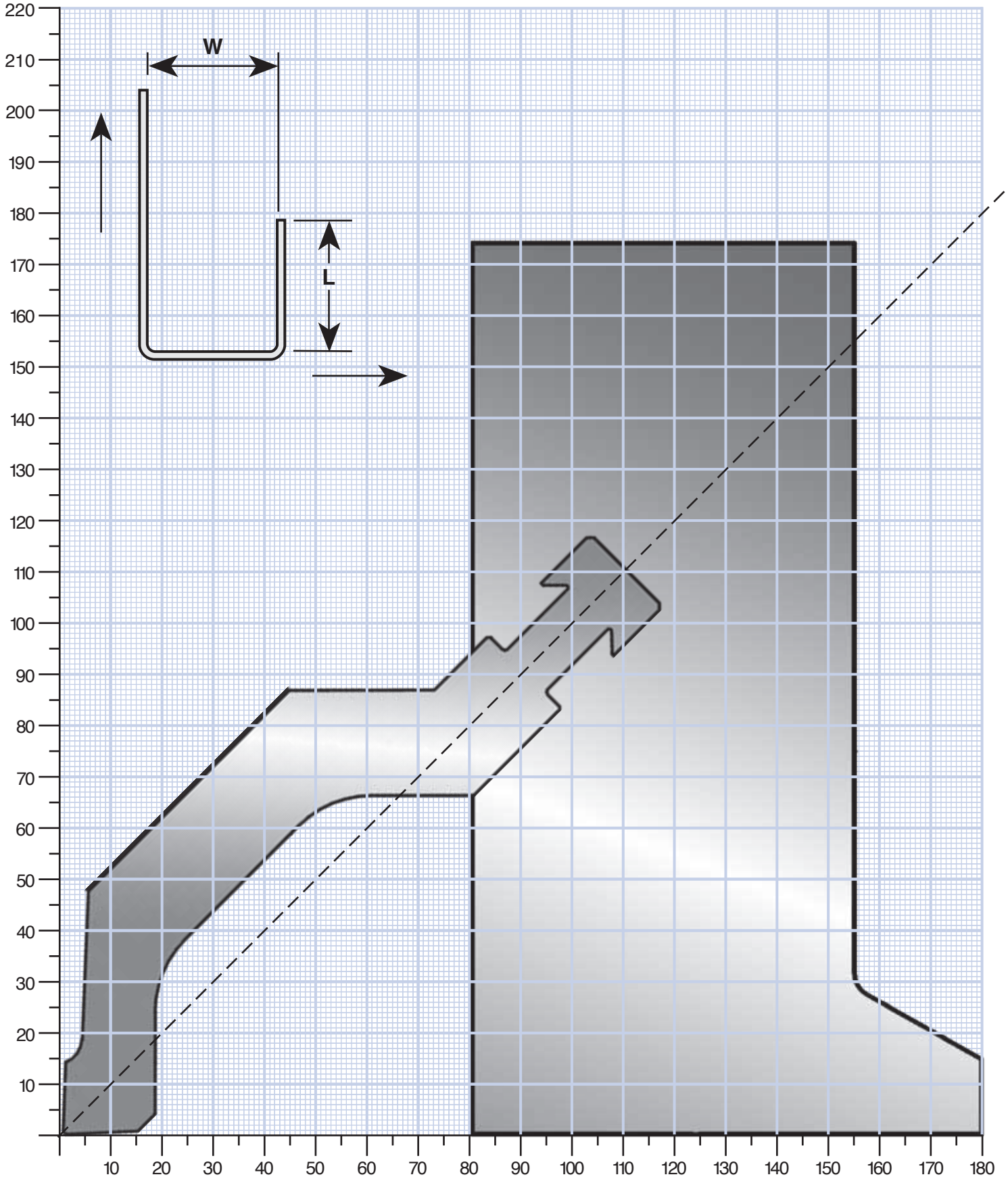

IB0460040

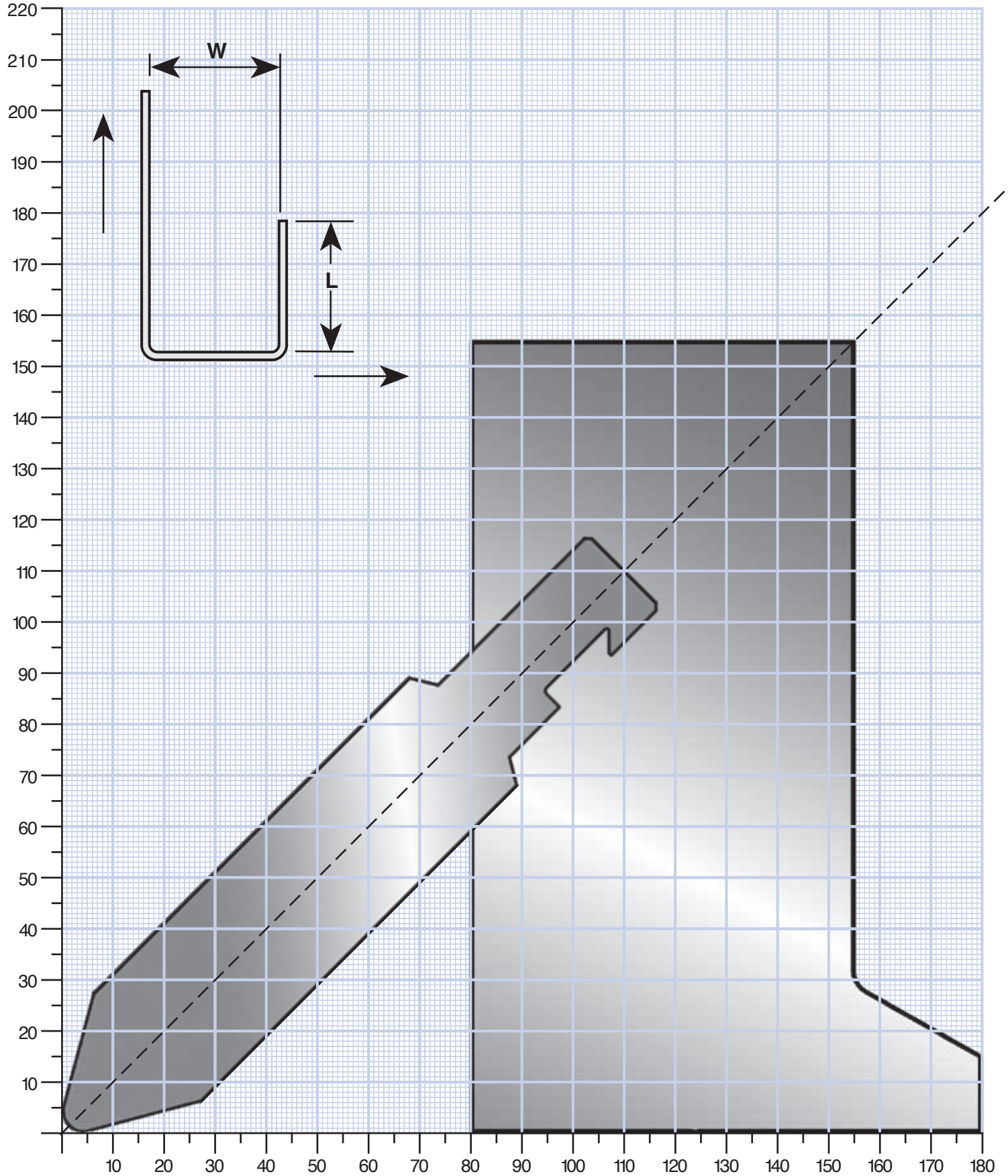

IB1188010, IB1185010

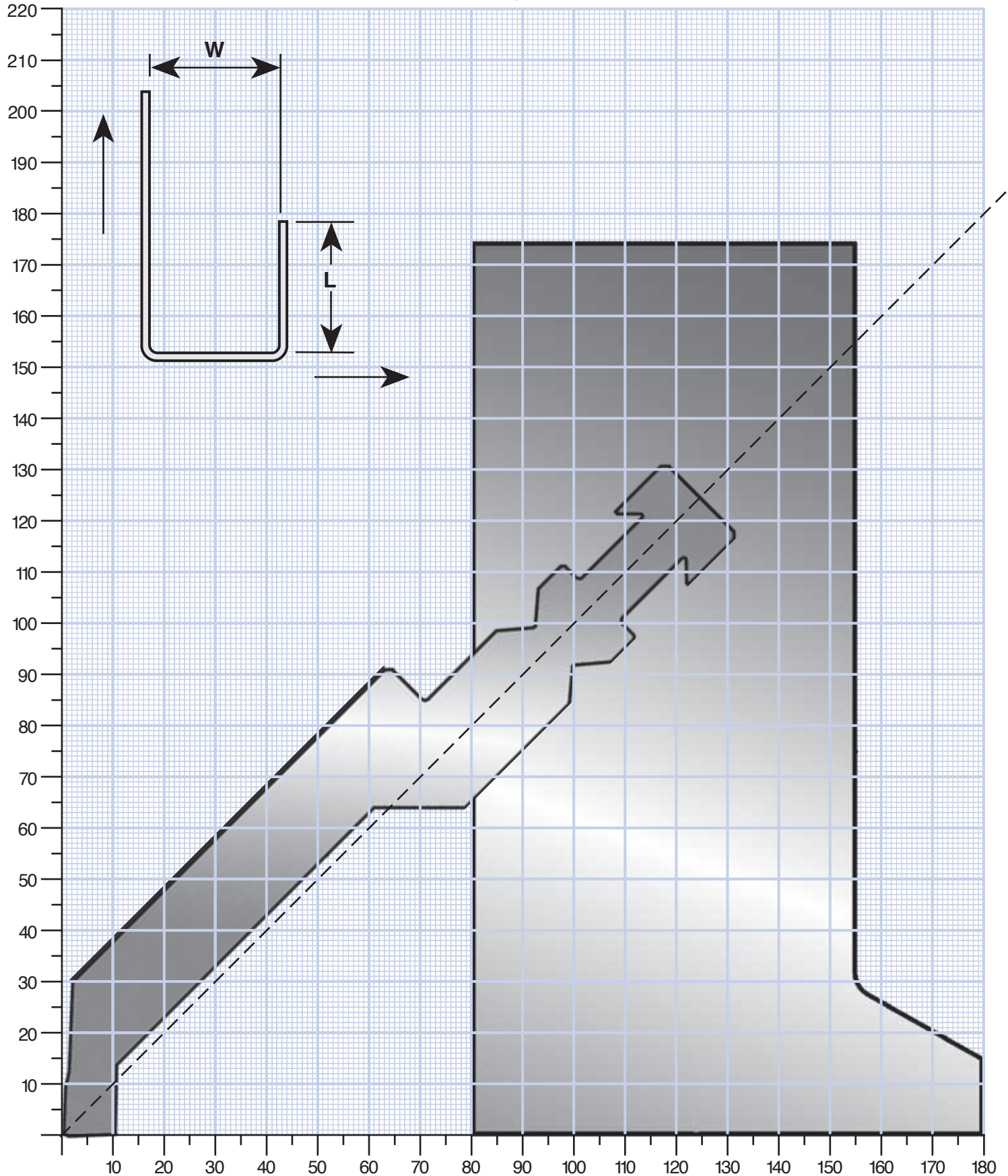

IB1088015, IB1085015

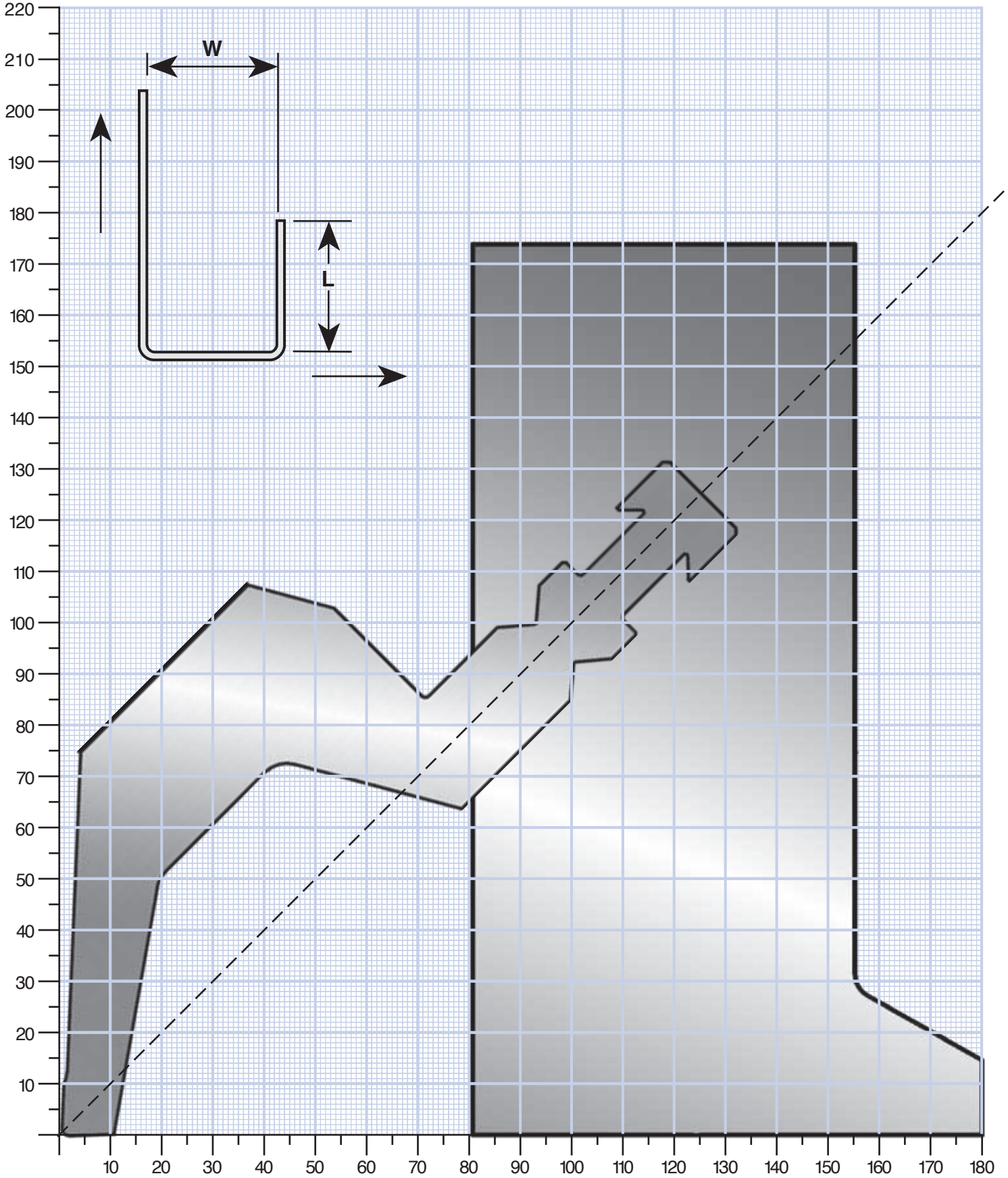

IB1230010

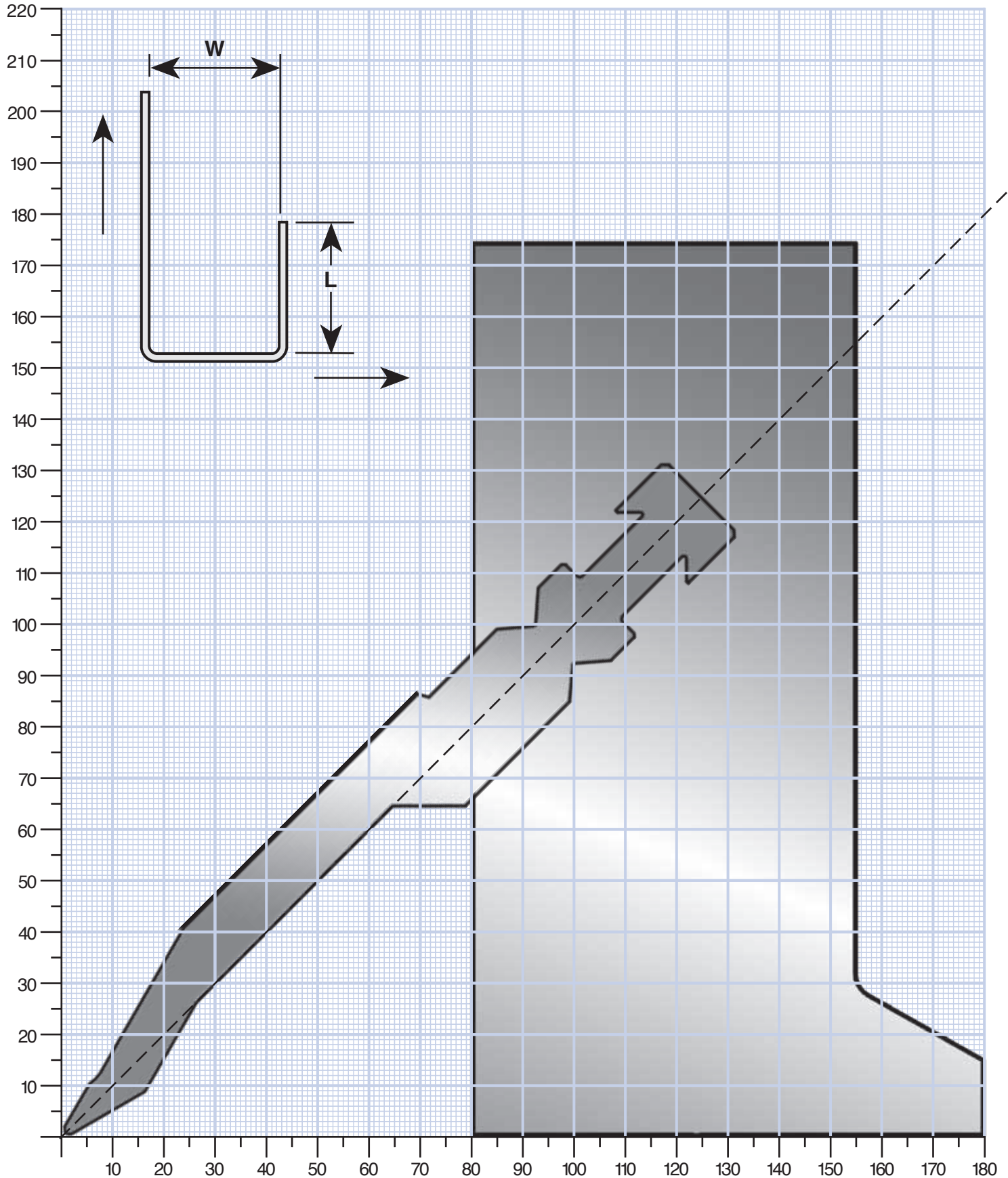

IB1430010

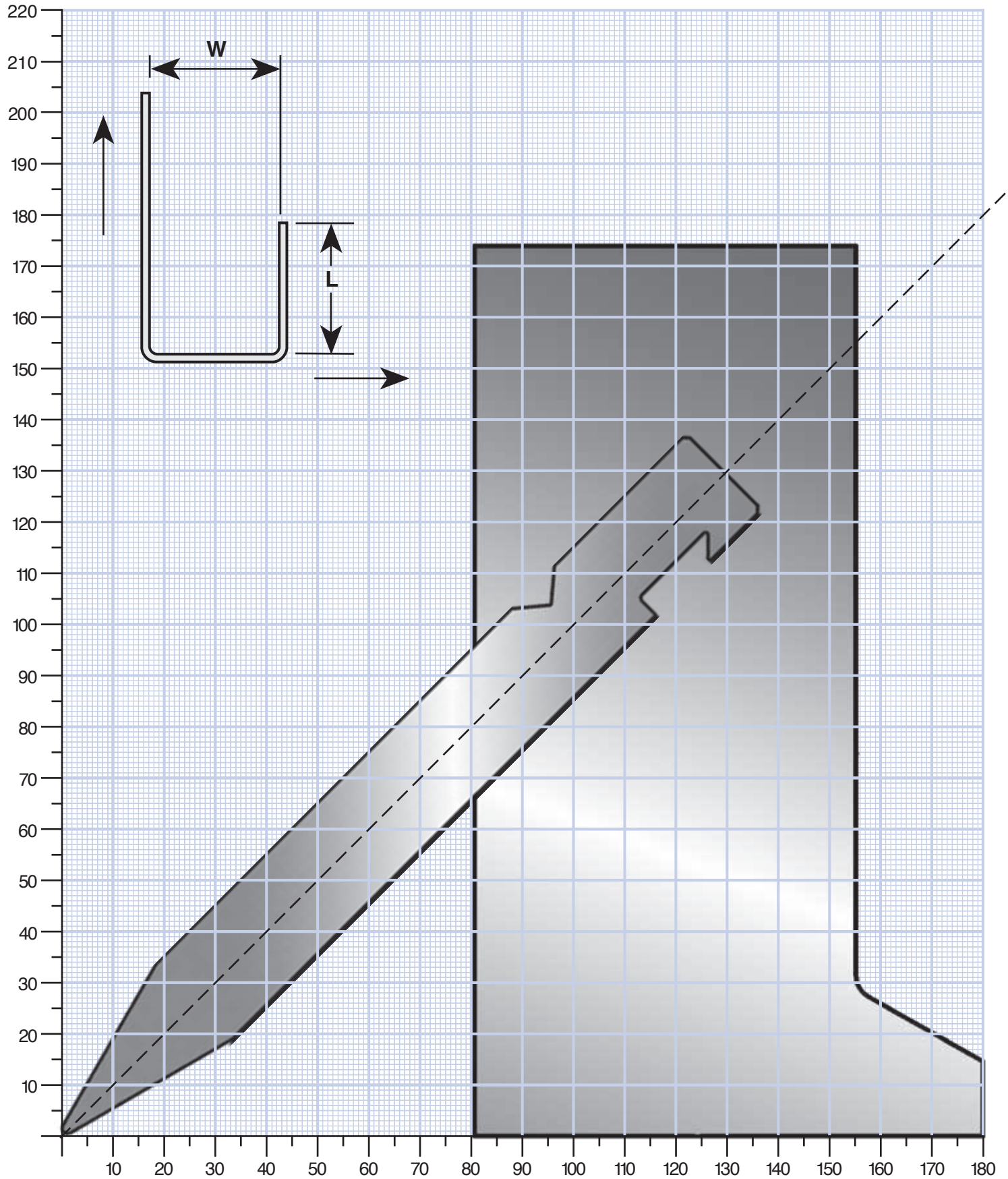

Bend Limit Graph

IB1588010, IB1585010

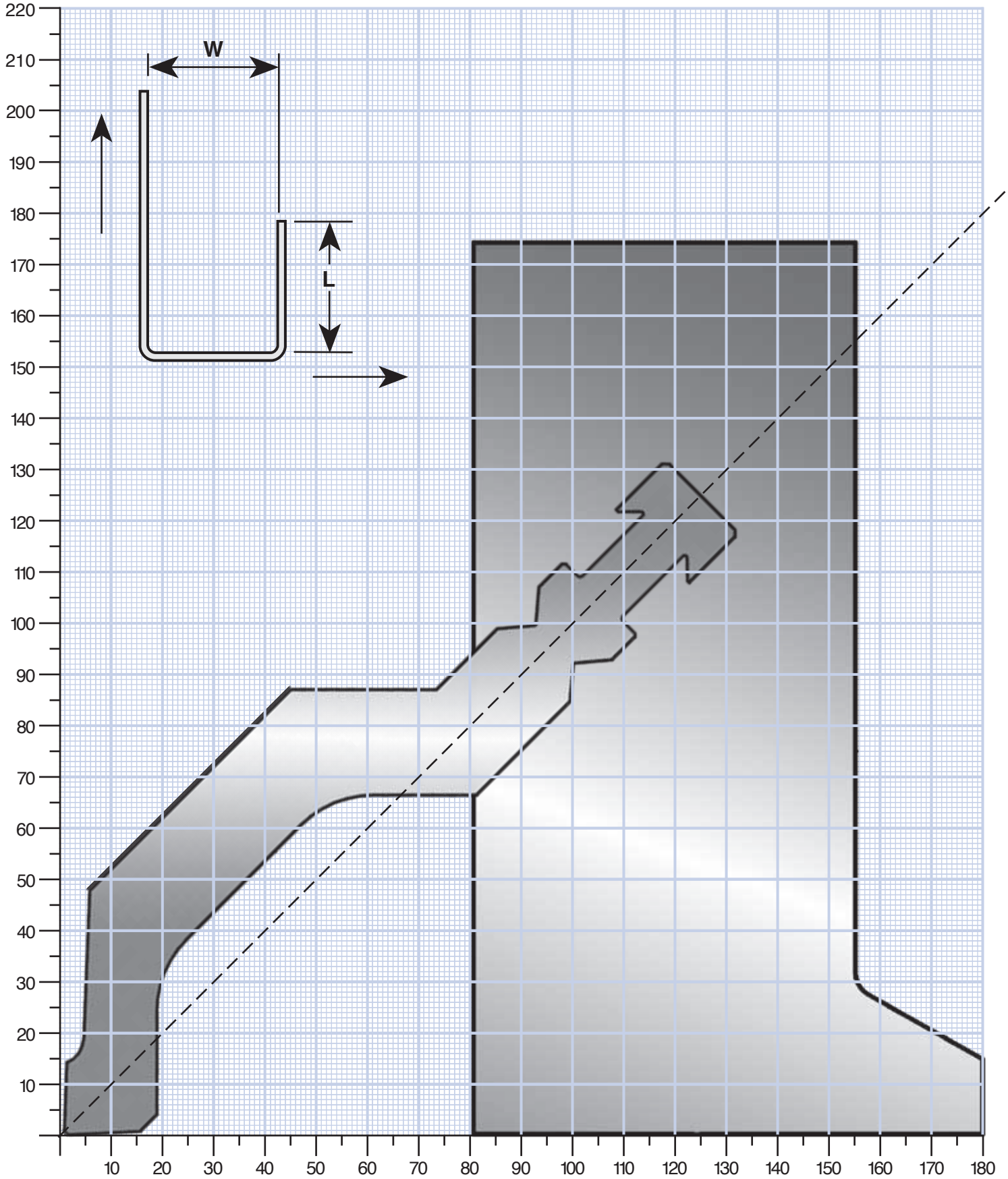

IB1460040

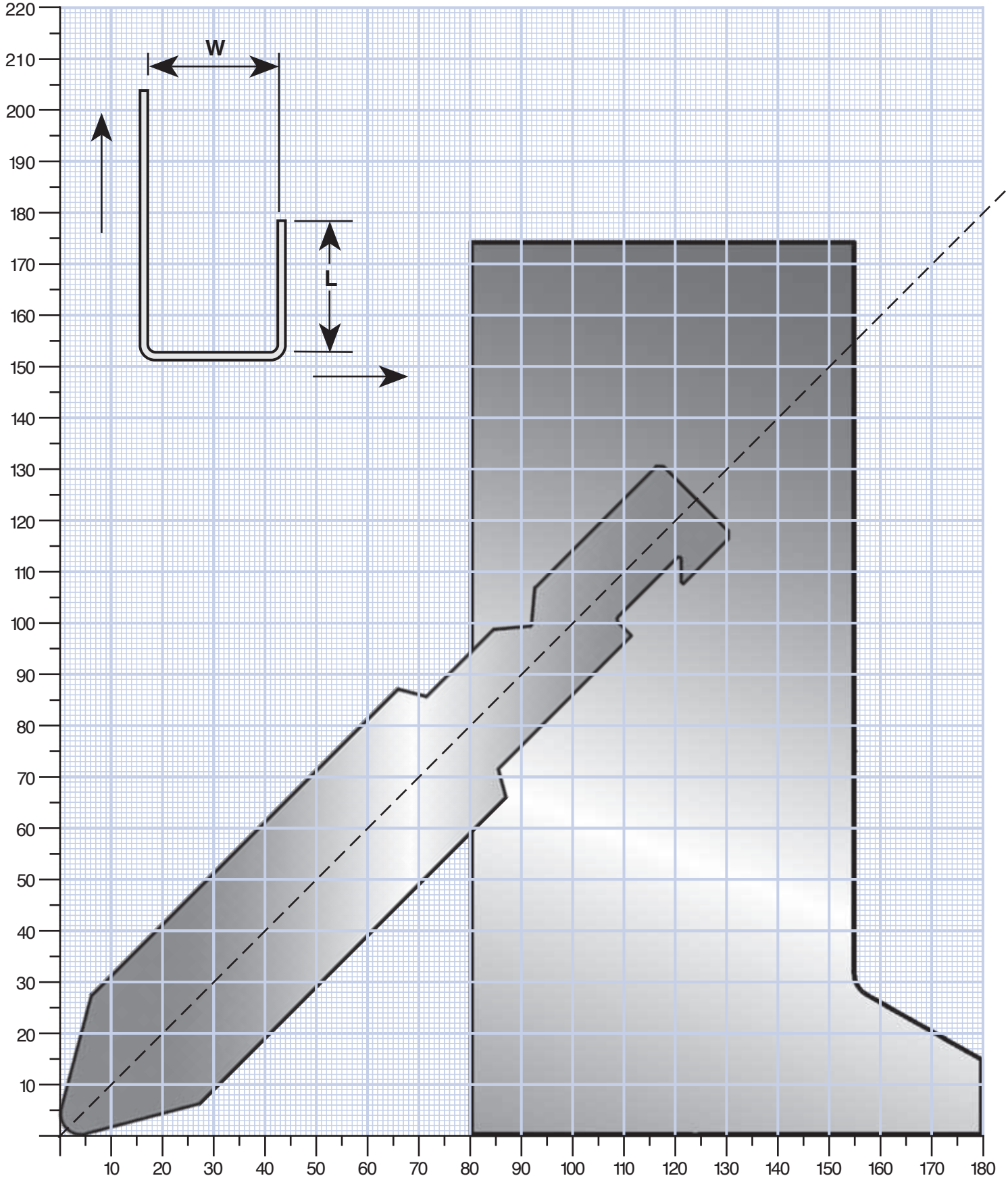

Bend Limit Graph

IB2188010, IB2185010

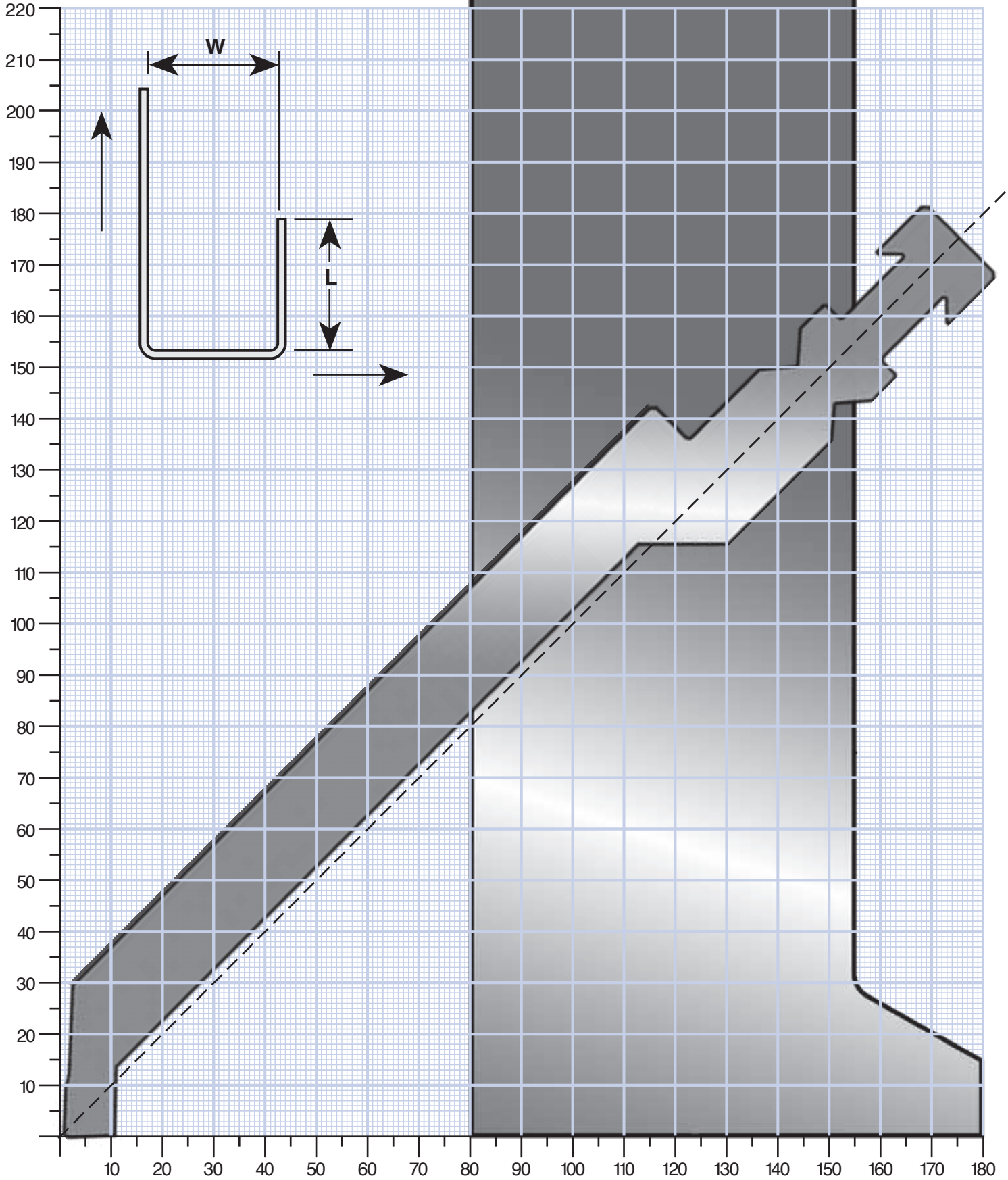

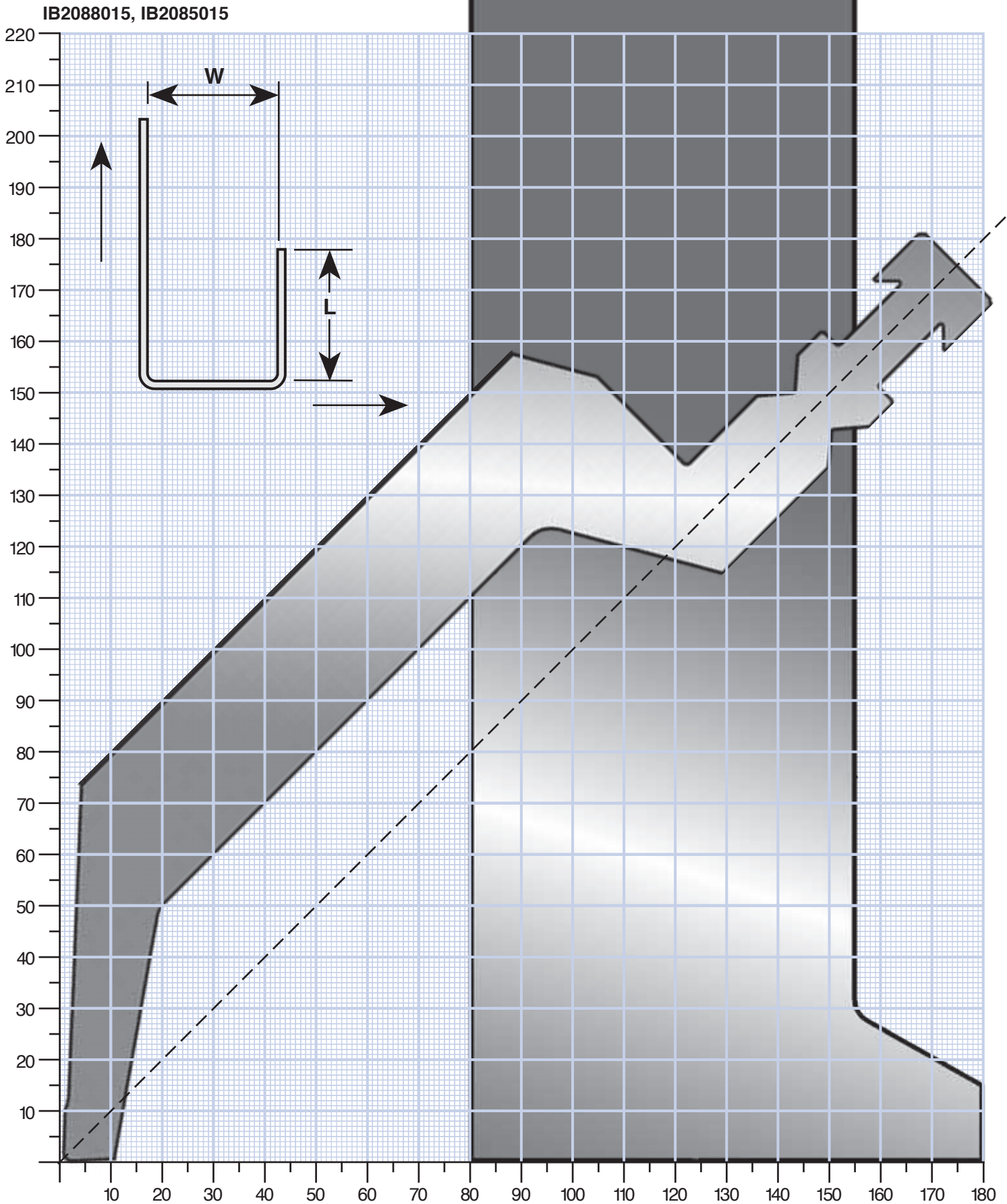

Bend Limit Graph

IB2230010

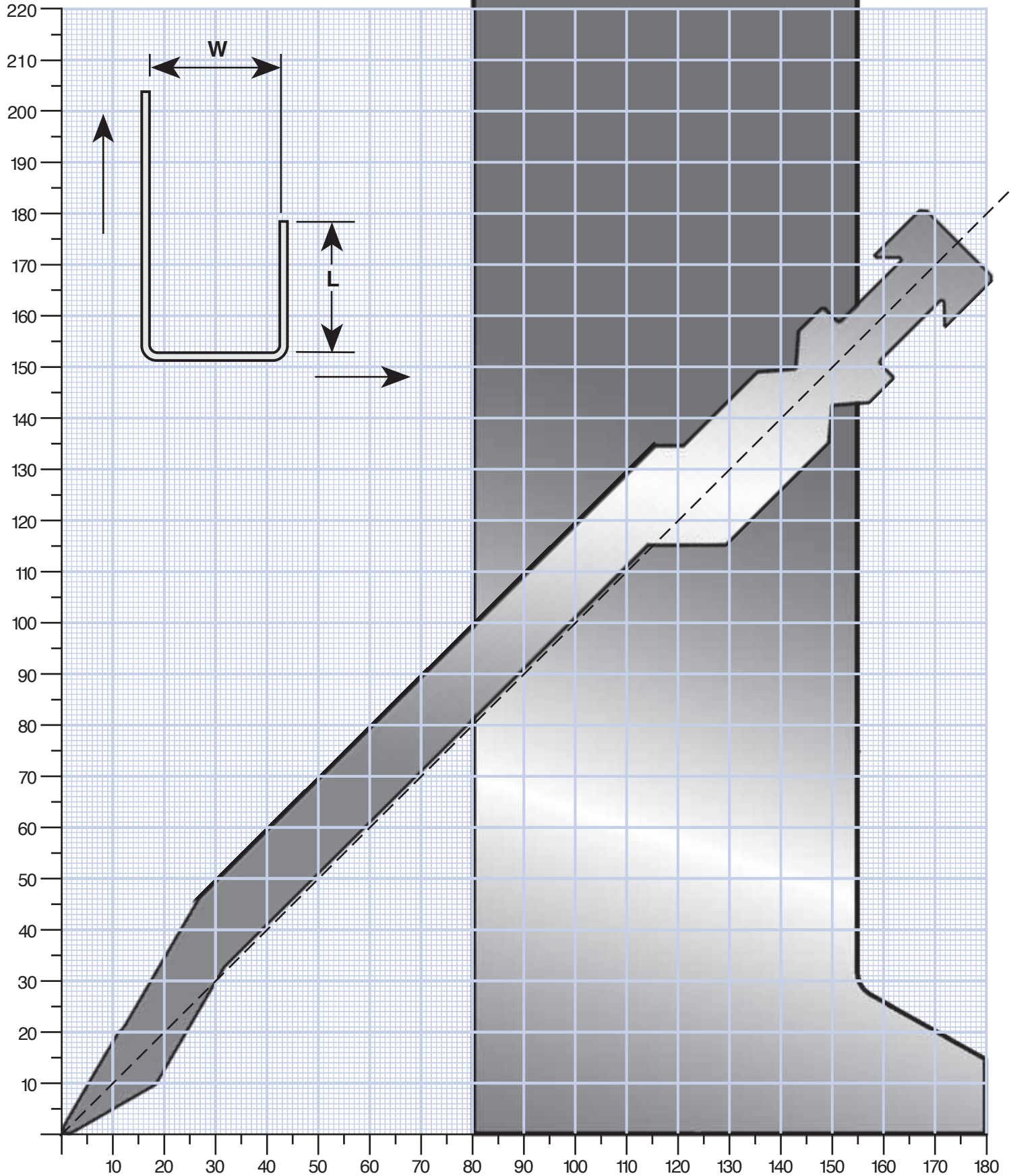



IB2430010

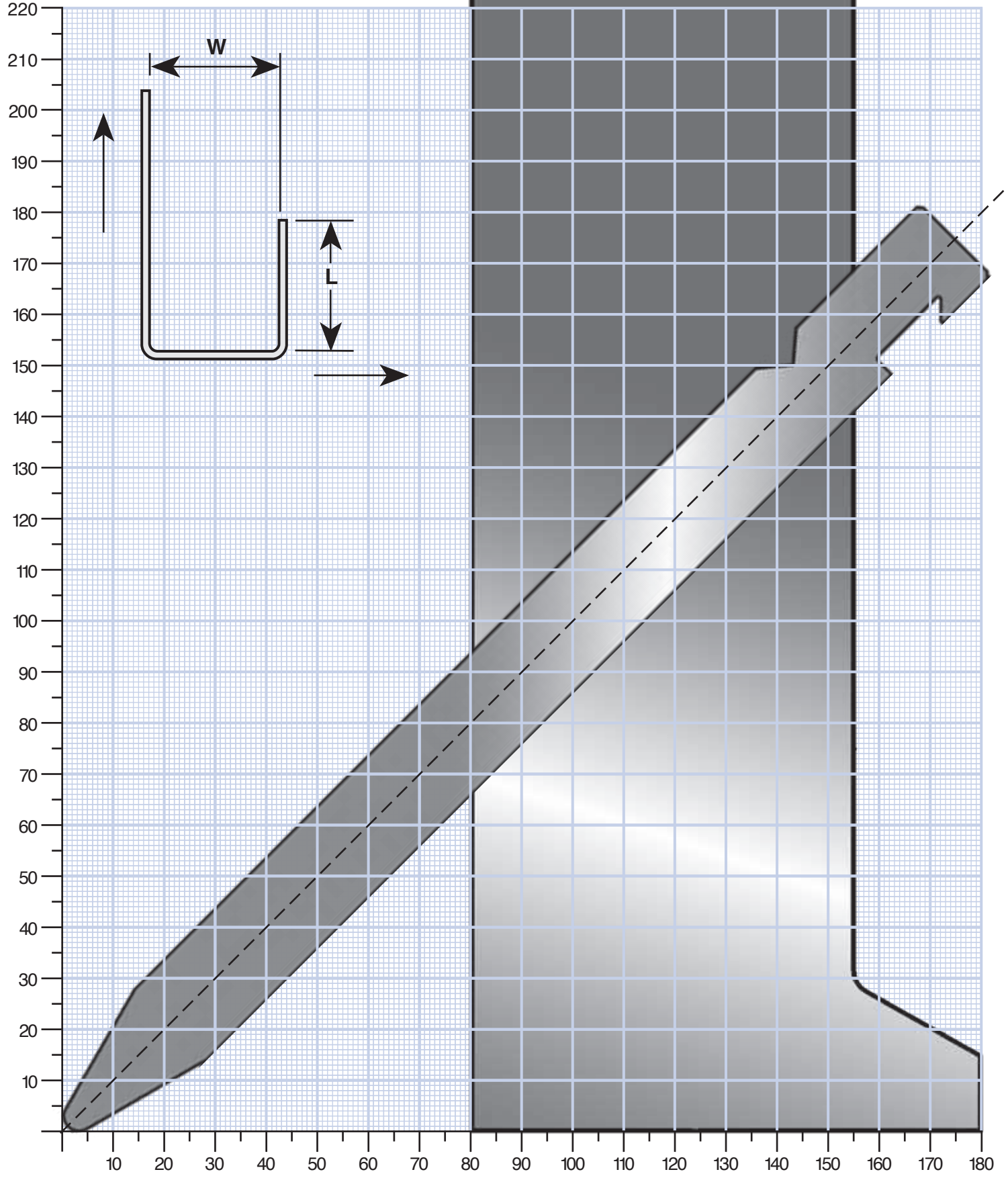

Bend Limit Graph

IB2460040

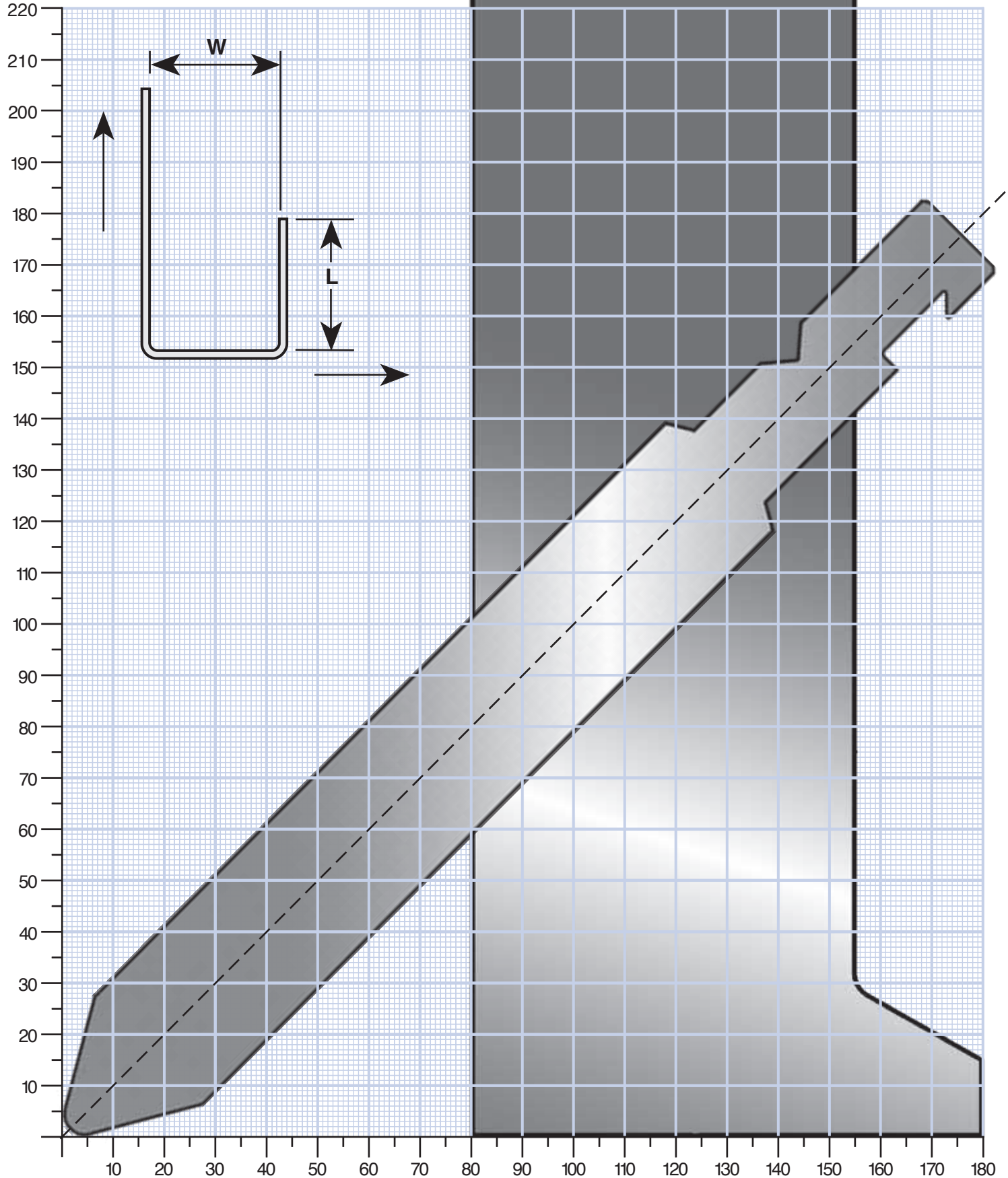

IB0330010-6, IB0330010-8, IB0330010-10, IB0330010-12, IB1330010-6, IB1330010-8, IB1330010-10, IB1330010-12

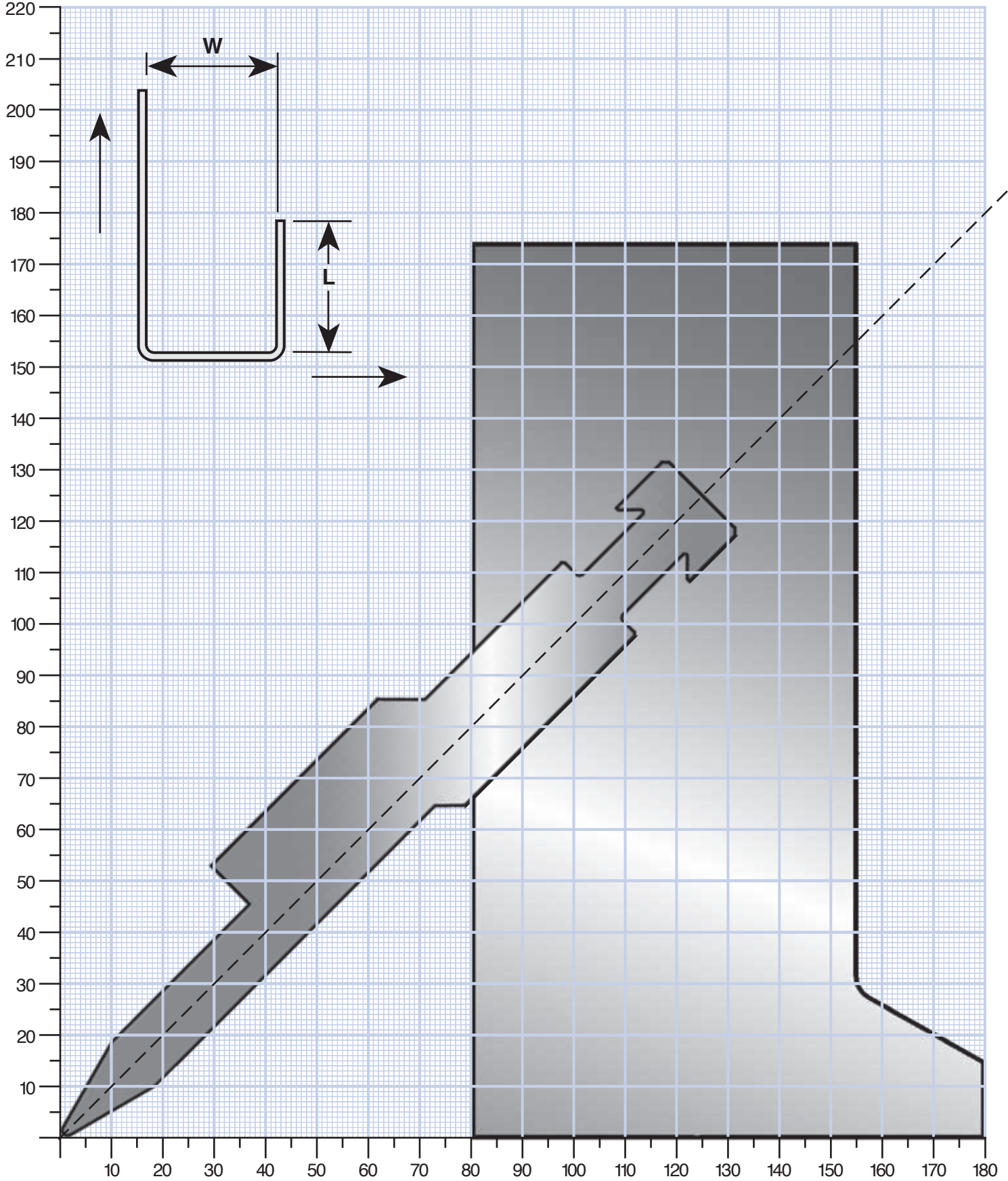



AIR BENDING FORCE CHART



C&P ENGINEERING
PROCUREMENT LDA

www.cep-ep.pt | info@cep-ep.pt

		Bending force-force in kN/1m bending length																												
		Minimum flange in mm																												
V	IR	6	8	10	12	16	18	20	24	25	32	35	40	50	60	63	80	100	120	130	140	150	160	180	190	200	230	260	290	320
t	F																													
	MF																													
0.5	25																													
	4.3																													
0.8	70	48																												
	4.6	5.7																												
1	115	80	60																											
	5	6	7																											
1.2		120	90	70																										
	6	7.5	8.5																											
1.5		150	120																											
	8	9																												
2.0		235	160	135	120	95																								
	10	14.5	17																											
2.5		265	225	200	155	117																								
	12.5	14	15.5	17.5	18	23																								
3.0		300	240	225	165	145	125																							
	15.5	17.5	18.5	23.5	25	28																								
4.0		440	315	280	235	180																								
	19.5	25	26	29	35																									
5.0		535	470	430	310	250																								
	26	28	31	35.5	43																									
6.0		610	450	360	340																									
	32	36	44	45																										
8.0		680	690	650	470	360																								
	40	46	48	57	71																									
10		1100	800	600	470	430	390																							
	50	60	71	85	92	100																								
12		1200	900	710	650	580	500																							
	62	73	86	92	100	105	115																							
16		1400	1250	1030	810	800	710	600																						
	90	98	105	110	115	130	135	140	160																					
18		1480	1350	1250	1100	1000	950	800	700	600																				
	105	110	120	130	135	140	160	180	205																					
20		1400	1300	1200	1000	900	850	700																						
	135	140	145	165	180	205	225																							

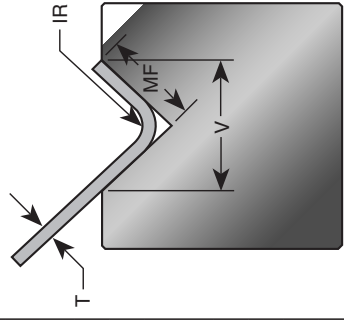

The bending force (tonnage) figures listed above are based on mild steel with a tensile strength of 45-50 kilograms per square millimetre. To calculate the approximate bending force (tonnage) requirements for other materials, please use the multipliers listed.

- Soft Brass
- Soft Aluminium
- Heat Treated Aluminium Alloys
- Stainless Steel
- Tons Per Metre x 50%
- Tons Per Metre x 50%
- Tons Per Metre x 100%
- Tons Per Metre x 150%

TOOLSPRESS IN THE WORLD



tools  **press**

Tp Tooling srl - Via Argini, 23 - S. Maria del Piano - 43037 Lesignano de' Bagni - Parma - ITALY
Tel: +39 0521 850510 - Fax: +39 0521 850796
E-mail: sales@toolspress.com
skype: sales.toolspress



**C&P ENGINEERING
PROCUREMENT LDA**

www.cep-ep.pt | info@cep-ep.pt

www.toolspress.com